



**Scottish & Southern
Electricity Networks**

Scottish Hydro Electric Power Distribution plc

Use of System Charging Statement

NOTICE OF CHARGES

Effective from 1st April 2022

Version 1.2

**The form of this statement was
approved by the Gas and Electricity
Markets Authority on 30 March
2021**

Version Control

Version	Date	Description of version and any changes made
V 1.0	01/04/2022	SHEPD DUoS Charges Final April 2022 (LC14 format)
V 1.1	01/04/2022 revised January 2022	Annex 2 – Addition of new MPANs and updated LLFCs/MSIDs Annex 5 – Updated generic and site specific LLFC/MSID and LLFs as per the 2022/23 approved LLFs Annexes 1 & 4 – The fixed charge for the Domestic Aggregated with Residual tariffs updated for the recovery of an Excess Specified Amount relating to the Last Resort Supply Payment (LRSP) claims. Details of the change can be found in Annex 7. No other tariffs affected by this change.
V 1.2	01/04/2022 revised May 2022	Text updated in paragraph 2.20 - approved by Ofgem 04/05/2022 Annex 2 – MPANs updated for Tariff 436 Annex 6 – Addition of new or amended charges and/or LLFs

A change-marked version of this statement can be provided upon request.

Contents

- 1. Introduction..... 5
 - Validity period..... 5
 - Contact details 6
- 2. Charge Application and Definitions..... 7
 - Supercustomer Billing and Payment..... 7
 - Supercustomer Charges..... 7
 - Site-Specific Billing and Payment..... 8
 - Site-Specific Billed Charges 8
 - Time Periods 9
 - Application of Capacity Charges 9
 - Chargeable Capacity 9
 - Exceeded Capacity 9
 - Demand Exceeded Capacity..... 10
 - Generation Exceeded Capacity 10
 - Standby Capacity for Additional Security on Site 10
 - Minimum Capacity Levels 10
 - Application of charges for reactive power..... 10
 - Demand Chargeable Reactive Power..... 11
 - Generation Chargeable Reactive Power 11
 - Allocation of Charges 11
 - Generation Charges for Pre-2005 designated EHV properties 12
 - Provision of billing data 12
 - Out of Area Use of System Charges..... 13
 - Licensed Distributor Network Operator charges 13
 - Licence exempt distribution networks 13
 - Full settlement metering 13
 - Difference metering..... 14
 - Gross settlement..... 14
- 3. Schedule of Charges for use of the Distribution System 15
- 4. Schedule of Line Loss Factors 16
 - Role of Line Loss Factors in the Supply of Electricity 16
 - Calculation of Line Loss Factors 16
 - Publication of Line Loss Factor tables..... 16
- 5. Notes for Designated EHV Properties 17
 - EDCM network group costs 17
 - Charges for New Designated EHV Properties 17
 - Charges for Amended Designated EHV Properties 17
 - Demand Side Management 17
- 6. Electricity Distribution Rebates 18
- 7. Accounting and Administration Services..... 19
- 8. Charges for electrical plant provided ancillary to the grant of Use of System 20
- 9. Schedule of fixed adders to recover Supplier of Last Resort and Eligible Bad Debt pass-through costs 21
 - Supplier of Last Resort 21
 - Excess Supplier of Last Resort..... 21
 - Eligible Bad Debt 21
 - Tables of Fixed Adders 21
- 10. Non-Final Demand Sites 22
- Appendix 1 – Glossary..... 23

Appendix 2 - Guidance notes	29
Background	29
Meter point administration	29
Your charges	30
Reducing your charges.....	30
Reactive power and reactive power charges.....	30
Site-specific EDCM charges.....	31
Additional Notes	33
Appendix 3 – Non-Final Demand Site Certificate.....	34
Annex 1 - Schedule of Charges for use of the Distribution System by LV and HV Designated Properties.....	35
Annex 2 - Schedule of Charges for use of the Distribution System by Designated EHV Properties (including LDNOs with Designated EHV Properties/end-users).....	39
Annex 3 - Schedule of Charges for use of the Distribution System by Preserved/Additional LLF Classes	49
Annex 4 - Charges applied to LDNOs with HV/LV end users.....	50
Annex 5 – Schedule of Line Loss Factors.....	66
LLF time periods:.....	66
Annex 6 – Charges for New or Amended Designated EHV Properties.....	77
Annex 7 – Supplier of last Resort and Eligible Bad Debt Pass-Through Costs.....	80

1. Introduction

- 1.1 This statement tells you about our charges and the reasons behind them. It has been prepared consistent with Standard Licence Condition 14 of our Electricity Distribution Licence. The main purpose of this statement is to provide our schedule of charges¹ for the use of our Distribution System and to provide the schedule of Line Loss Factors² that should be applied in Settlement to account for losses from the Distribution System. We have also included guidance notes in Appendix 2 to help improve your understanding of the charges we apply.
- 1.2 Within this statement we use terms such as 'Users' and 'Customers' as well as other terms which are identified with initial capitalisation. These terms are defined in the Glossary.
- 1.3 The charges in this statement are calculated using the following methodologies as per the Distribution Connection and use of system Agreement (DCUSA)³:
 - Common Distribution Charging Methodology (CDCM); for Low Voltage (LV) and High Voltage (HV) Designated Properties as per DCUSA Schedule 16; and
 - Extra-High Voltage (EHV) Distribution Charging Methodology (EDCM) for Designated EHV Properties as per DCUSA Schedule 17.
 - Price Control Disaggregation Model (PCDM); for Discount Percentages used to calculate the LDNO Use of System charges in the CDCM and EDCM as per DCUSA Schedule 29.
- 1.4 Separate charges are calculated depending on the characteristics of the connection and whether the use of the Distribution System is for demand or generation purposes. Where a generation connection is seen to support the Distribution System the charges will be negative and the Supplier will receive credits for exported energy.
- 1.5 The application of charges to premises can usually be referenced using the Line Loss Factor Class (LLFC) contained in the charge tables. Further information on how to identify and calculate the charge that will apply for your premises is provided in the guidance notes in Appendix 2.
- 1.6 All charges in this statement are shown **exclusive** of VAT. Invoices will include VAT at the applicable rate.
- 1.7 The annexes that form part of this statement are also available in spreadsheet format. This spreadsheet contains supplementary information used for charging purposes and a simple model to assist you to calculate charges. This spreadsheet can be downloaded from our website www.ssen.co.uk.

Validity period

- 1.8 This charging statement is valid for services provided from the effective date stated on the front of the statement and remains valid until updated by a revised version or superseded by a statement with a later effective date.
- 1.9 When using this charging statement care should be taken to ensure that the relevant statement or statements covering the period that is of interest are used.
- 1.10 Notice of any revision to the statement will be provided to Users of our Distribution System (with the exception of updates to Annex 6; New or Amended EHV Sites which will be published as an addendum). The latest statements can be downloaded from www.ssen.co.uk.

¹ Charges can be positive or negative.

² Known as adjustment factors in the Distribution Licence and commonly referred to as Loss Adjustment Factors. The schedule of Line Loss Factors will be provided in a revised statement shortly after the Line Loss Factors for the relevant year have been successfully audited by Elexon

³ The Distribution and Connection Use of System Agreement (DCUSA) available from <https://www.dcosa.co.uk/dcosa-document/>

Contact details

1.11 If you have any questions about this statement please contact us at the address shown below:

Distribution Pricing Team
Scottish Hydro Electric Power Distribution plc
Inveralmond House
200 Dunkeld Road
Perth
PH1 3AQ
Email: DistributionPricingTeam@sse.com

1.12 All enquiries regarding Connection Agreements, changes to Maximum Capacities, and certification of Storage Facilities should be addressed to:

Email: authorised.capacity@sse.com

Post:
Authorised Capacity
Scottish and Southern Electricity Networks
Daneshill Depot
Faraday Road
Basingstoke
RG24 8QQ

1.13 For all other queries please contact our general enquiries telephone number: 0800 048 3516.

2. Charge Application and Definitions

- 2.1 The following section details how the charges in this statement are applied and billed to Users of our Distribution System.
- 2.2 We utilise two billing approaches depending on the type of metering data received:
- (a) The 'Supercustomer' approach for Customers for whom we receive aggregated consumption data through Settlement; and
 - (b) The 'Site-specific' approach for Customers for whom we receive site-specific consumption data through Settlement.
- 2.3 We receive aggregated consumption data through Settlement for:
- (a) Domestic and non-domestic Customers for whom Non-Half Hourly (NHH) metering data is used in Settlement (i.e. Customers with MPANs which are registered to Measurement Class A);
 - (b) Customers which are unmetered and are not settled as pseudo Half Hourly (HH) metered (i.e. Customers with MPANs which are registered to Measurement Class B);
 - (c) Domestic Customers for whom HH metering data is used in Settlement (i.e. Customers with MPANs which are registered to Measurement Class F); and
 - (d) Non-domestic Customers for whom HH metering data is used in Settlement and which have whole current (WC) metering (i.e. Customers with MPANs which are registered to Measurement Class G).
- 2.4 We receive site specific consumption data through Settlement for:
- (a) Customers for whom HH metering data is used in Settlement and which have current transformer (CT) metering (i.e. Customers with MPANs which are registered to measurement class C or E); and
 - (b) Customers which are unmetered and settled as pseudo HH metered (i.e. Customers with MPANs which are registered to measurement class D).

Supercustomer Billing and Payment

- 2.5 The Supercustomer approach makes use of aggregated data obtained from Suppliers using the 'Aggregated Distribution Use of System (DUoS) Report' data flow.
- 2.6 Invoices are calculated on a periodic basis and sent to each User for whom we transport electricity through our Distribution System. Invoices are reconciled, over a period of approximately 14 months to reflect later and more accurate consumption figures.
- 2.7 The charges are applied on the basis of the LLFC assigned to the MPAN, and the units consumed within the time periods specified in this statement. These time periods may not necessarily be the same as those indicated by the Time Pattern Regimes (TPRs) assigned to the Standard Settlement Configuration (SSC). All LLFCs are assigned at our sole discretion, based on the tariff application rules set out in the appropriate charging methodology or elsewhere in this statement. Please refer to the section 'Allocation of Charges' for further details.

Supercustomer Charges

- 2.8 Supercustomer charges are generally billed through the following components:
- a fixed charge, pence/MPAN/day; there will only be one fixed charge applied to each MPAN; and
 - unit charges, pence/kilowatt-hour (kWh); three unit charges will apply depending on the time of day and the type of tariff for which the MPAN is registered.
- 2.9 Users who wish to supply electricity for whom we receive aggregated data through Settlement (see paragraph 2.3) will be allocated the relevant charge structure set out in Annex 1.
- 2.10 Identification of the appropriate charge can be made by cross reference to the LLFC.

- 2.11 Valid Settlement Profile Class (PC) /Standard Settlement Class (SSC)/ Meter Timeswitch Code (MTC) combinations for LLFCs where the Metering System is Measurement Class A or B are detailed in Market Domain Data (MDD).
- 2.12 Where an MPAN has an invalid Settlement Combination, the 'Domestic Aggregated with Residual' fixed and unit charges will be applied as default until the invalid combination is corrected. Where there are multiple SSC/TPR combinations, the default 'Domestic Aggregated with Residual' fixed and unit charges will be applied for each invalid SSC/TPR combination.
- 2.13 The 'Domestic Aggregated (related MPAN)' and 'Non-Domestic Aggregated (related MPAN)' charges are supplementary to their respective primary MPAN charge.

Site-Specific Billing and Payment

- 2.14 The site-specific billing and payment approach makes use of HH metering data at premises level received through Settlement.
- 2.15 Invoices are calculated on a periodic basis and sent to each User for whom we transport electricity through our Distribution System. Where an account is based on estimated data, the account shall be subject to any adjustment that may be necessary following the receipt of actual data from the User.
- 2.16 The charges are applied on the basis of the LLFCs assigned to the MPAN or MSID for Central Volume Allocation (CVA) sites, and the units consumed within the time periods specified in this statement. Where MPANs have not been associated, for example when multiple points of connection fed from different sources are used for a single site, the relevant number of fixed charges will be applied.
- 2.17 All LLFCs are assigned at our sole discretion, based on the tariff application rules set out in the appropriate charging methodology or elsewhere in this statement. Please refer to the section 'Allocation of Charges' if you believe the allocated LLFC or tariff is incorrect.

Site-Specific Billed Charges

- 2.18 Site-specific billed charges for LV and HV Designated Properties may include the following components:
- a fixed charge in pence/MPAN/day for SVA sites, or pence/MSID/day for CVA sites;
 - a capacity charge in pence/kilovolt-ampere (kVA) /day, for Maximum Import Capacity (MIC) and/or Maximum Export Capacity (MEC);
 - an exceeded capacity charge in pence/kVA/day, if a site exceeds its MIC and/or MEC;
 - three unit charges in pence/kWh, depending on the time of day and the type of tariff for which the MPAN is registered; and
 - a reactive power charge in pence/kilovolt-ampere reactive hour (kVArh), for each unit in excess of the reactive charge threshold.
- 2.19 Users who wish to supply electricity to Customers for whom we receive site-specific data through Settlement (see paragraph 2.4) will be allocated the relevant charge structure dependent upon the voltage and location of the Metering Point.
- 2.20 Fixed charges are generally levied on a pence per MPAN/MSID per day basis.
- 2.21 LV and HV Designated Properties will be charged in accordance with the CDCM and allocated the relevant charge structure set out in Annex 1.
- 2.22 Designated EHV Properties will be charged in accordance with the EDCM and allocated the relevant charge structure set out in Annex 2.
- 2.23 Where LV and HV Designated Properties or Designated EHV Properties have more than one point of connection (as identified in the Connection Agreement) then separate charges will be applied to each point of connection.

Components of Charges

Application of Residual Charges

- 2.24 The following sections explain the application of residual charges.

Final Demand Sites

- 2.25 Residual charges are recovered through fixed charges for all Final Demand Sites. All Non-Final Demand Sites must submit a valid certificate, as described in Section 10, and upon receipt of a valid certificate will be allocated to the relevant No Residual Tariff.

Residual Charging Bands

- 2.26 Residual charges are applied to Final Demand Sites on a banded basis, with all sites in a given charge band receiving the same residual charge. Domestic customers have a single charging band.
- 2.27 There are four non-domestic charging bands for each of the following groups:
- Designated Properties connected at LV, billing with no MIC;
 - Designated Properties connected at LV, billing with MIC;
 - Designated Properties connected at HV; and
 - Designated EHV Properties.
- 2.28 All non-domestic Final Demand customers are allocated into one of the four charging bands, for each relevant charge structure.
- 2.29 The residual charging band boundaries are calculated nationally based upon data from all LDNOs. The method and timing for calculating the residual charging band boundaries and the method and timing for allocating customers into the residual charging bands are set out in Schedule 32 of DCUSA.
- 2.30 The boundaries for the residual bands can be found in the 'Schedule of Charges and Other Tables' spreadsheet on our website.

Time Periods

- 2.31 The time periods for the application of unit charges to LV and HV Designated Properties are detailed in Annex 1. We have not issued a notice to change the time bands.
- 2.32 The time periods for the application of unit charges to Unmetered Supply Exit Points are detailed in Annex 1. We have not issued a notice to change the time bands.
- 2.33 The time periods for the application of unit charges to Designated EHV Properties are detailed in Annex 2. We have not issued a notice to change the time bands.

Application of Capacity Charges

- 2.34 The following sections explain the application of capacity charges and exceeded capacity charges.

Chargeable Capacity

- 2.35 The chargeable capacity is, for each billing period, the MIC/MEC as detailed below.
- 2.36 The MIC/MEC will be agreed with us at the time of connection or pursuant to a later change in requirements. Following such an agreement (be it at the time of connection or later) no reduction in MIC/MEC will be allowed for a 12 month period.
- 2.37 Reductions to the MIC and/or MEC may only be permitted once in a 12 month period. Where the MIC/MEC is reduced the new lower level will be agreed with reference to the level of the Customer's maximum import and/or export demand respectively. The new MIC/MEC will be applied from the start of the next billing period after the date that the request was received. It should be noted that, where a new lower level is agreed, the original capacity may not be available in the future without the need for network reinforcement and associated charges.
- 2.38 In the absence of an agreement, the chargeable capacity, save for error or omission, will be based on the last MIC/MEC previously agreed by us for the relevant premises' connection. A Customer can seek to agree or vary the MIC/MEC by contacting us using the contact details in section 1.11.

Exceeded Capacity

- 2.39 Where a Customer takes additional unauthorised capacity over and above the MIC/MEC, the excess will be classed as exceeded capacity. The exceeded portion of the capacity will be charged at the exceeded capacity charge p/kVA/day rate, based on the difference between the MIC/MEC and the

actual capacity used. This will be charged for the duration of the full month in which the breach occurs.

Demand Exceeded Capacity

$$\text{Demand Exceeded Capacity} = \max(2 \times \sqrt{AI^2 + \max(RI, RE)^2} - MIC, 0)$$

Where:

AI = Active Import (kWh)

RI = Reactive Import (kVARh)

RE = Reactive Export (kVARh)

MIC = Maximum Import Capacity (kVA)

2.40 Only reactive import and reactive export values occurring at times of active import are used in the calculation.

2.41 This calculation is completed for every half hour and the maximum value from the billing period is applied.

Generation Exceeded Capacity

$$\text{Generation Exceeded Capacity} = \max(2 \times \sqrt{AE^2 + \max(RI, RE)^2} - MEC, 0)$$

Where:

AE = Active Export (kWh)

RI = Reactive Import (kVARh)

RE = Reactive Export (kVARh)

MEC = Maximum Export Capacity (kVA)

2.42 Only reactive import and reactive export values occurring at times of active export are used in the calculation.

2.43 This calculation is completed for every half hour and the maximum value from the billing period is applied.

Standby Capacity for Additional Security on Site

2.44 Where standby capacity charges are applied, the charge will be set at the same rate as that applied to the normal MIC. Should a Customer's request for additional security of supply require the provision of capacity from two different sources, we reserve the right to charge for the capacity held at each source.

Minimum Capacity Levels

2.45 There is no minimum capacity threshold.

Application of charges for reactive power

2.46 When an individual HH metered MPAN's reactive power (measured in kVARh) at LV and HV Designated Properties exceeds 33% of its total active power (measured in kWh), reactive power charges will apply. This threshold is equivalent to an average power factor of 0.95 during the period. Any reactive units in excess of the 33% threshold are charged at the rate appropriate to the particular charge.

2.47 Power Factor is calculated as follows:

$\text{Cos } \theta = \text{Power Factor}$

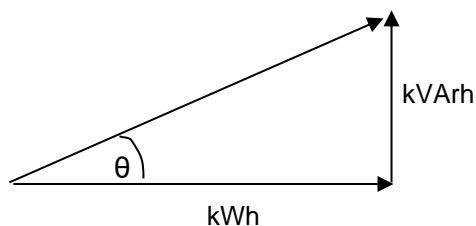

2.48 The chargeable reactive power is calculated as follows:

Demand Chargeable Reactive Power

$$\text{Demand Chargeable kVArh} = \max \left(\max(\text{RI}, \text{RE}) - \left(\sqrt{\left(\frac{1}{0.95^2} - 1 \right)} \times \text{AI} \right), 0 \right)$$

Where:

AI = Active Import (kWh)

RI = Reactive Import (kVArh)

RE = Reactive Export (kVArh)

2.49 Only reactive import and reactive export values occurring at times of active import are used in the calculation.

2.50 The square root calculation will be to two decimal places.

2.51 This calculation is completed for every half hour and the values summated over the billing period.

Generation Chargeable Reactive Power

$$\text{Generation Chargeable kVArh} = \max \left(\max(\text{RI}, \text{RE}) - \left(\sqrt{\left(\frac{1}{0.95^2} - 1 \right)} \times \text{AE} \right), 0 \right)$$

Where:

AE = Active Export (kWh)

RI = Reactive Import (kVArh)

RE = Reactive Export (kVArh)

2.52 Only reactive import and reactive export values occurring at times of active export are used in the calculation.

2.53 The square root calculation will be to two decimal places.

2.54 This calculation is completed for every half hour and the values summated over the billing period.

Allocation of Charges

2.55 It is our responsibility to apply the correct charges to each MPAN/MSID. The allocation of charges is based on the voltage of connection, import/export details including multiple MPANs, metering information and, for some tariffs, the metering location. Where an MPAN/MSID is used for export purposes in relation to an LV or HV Designated Property, the type of generation (Intermittent or Non-Intermittent) also determines the allocation of charges.

2.56 We are responsible for deciding the voltage of connection. Generally, this is determined by where the metering is located and where responsibility for the electrical equipment transfers from us to the connected Customer.

2.57 We are also responsible for allocating non-domestic customers into their residual charging bands. Allocation into residual charging bands is determined by consumption for customers billed under the Supercustomer approach and by the MIC for customers billed under the site-specific approach.

2.58 The Supplier determines and provides us with the metering information and data. This enables us to allocate charges where there is more than one charge per voltage level. The metering information and data is likely to change over time if, for example, a Supplier changes from a two rate meter to a single rate meter. When we are notified this has happened we will change the allocation of charges accordingly.

2.59 If it has been identified that a charge has been incorrectly allocated due to the metering information and/or data then a correction request should be made to the Supplier.

2.60 Where it has been identified that either:

(a) a charge is likely to be incorrectly allocated due to the voltage of connection, import/export details or metering location, or allocation to residual charging band; or

(b) a connection may be eligible for Low Voltage Substation tariff(s);

a request to investigate the applicable charges should be made to us. Requests from persons other than the Customer or the current Supplier must be accompanied by a Letter of Authority from the Customer and the current Supplier must also acknowledge that they are aware a request has been made. Any request must be supported by an explanation of why it is believed that the current charge should be changed, along with supporting information including, where appropriate, photographs of metering positions or system diagrams. Any request to change the current charge that also includes a request for backdating must include justification as to why it is considered appropriate to backdate the change.

- 2.61 Where a residual charging band allocation cannot be resolved, the process provided within DCUSA Schedule 32 should be followed.
- 2.62 An administration charge (covering our reasonable costs) may be made if a technical assessment or site visit is required, but we will not apply any charge where we agree to the change request.
- 2.63 Where we agree that the current LLFC/charge should be changed, we will then allocate the appropriate set of charges for the connection. Any adjustment will be applied from the date of the request back to either:
- (a) the date of incorrect allocation in respect of paragraphs 2.59 or 2.60(a); or
 - (b) the date the connection first became eligible for a Storage Facility or Low Voltage Substation tariff(s) in respect of paragraph 2.60(b); or
 - (c) up to the maximum period specified by the Prescription and Limitation (Scotland) Act 1973 in Scotland, which covers a five year period;
- whichever is the shorter.
- 2.64 Any credit or additional charge will be issued to the relevant Supplier(s) effective during the period of the change.
- 2.65 Should we reject the request a justification will be provided to the requesting Party. We shall not unreasonably withhold or delay any decision on a request to change the charges applied and would expect to confirm our position on the request within three months of the date of request.

Generation Charges for Pre-2005 designated EHV properties

- 2.66 Designated EHV Properties that were connected to the Distribution System under a pre-2005 connection charging policy are eligible for exemption from DUoS charges for generation unless one of the following criteria has been met:
- 25 years have passed since their first energisation/connection date, i.e. Designated EHV Properties with Connection Agreements dated prior to 1st April 2005, and for which 25 years has passed since their first energisation/connection date will receive use of system charges for generation from the next charging year following the expiry of their 25 years exemption starting 1st April, or
 - the person responsible for the Designated EHV Property Customer has provided notice to us that they wish to opt in to DUoS charges for generation.
 - If a notice to opt in has been provided there will be no further opportunity to opt out.
- 2.67 Furthermore, if an exempt Customer makes an alteration to its export requirement then the Customer may be liable to be charged for the additional capacity required for energy imported or exported. For example, where a generator increases its export capacity the incremental increase in export capacity will attract DUoS charges as with other non-exempt generators.

Provision of billing data

- 2.68 Where HH metering data is required for DUoS charging and this is not provided in accordance with the BSC or DCUSA, such metering data shall be provided by the User of the system to us in respect of each calendar month within five working days of the end of that calendar month.
- 2.69 The metering data shall identify the amount of energy conveyed across the Metering System in each half hour of each day and shall separately identify active and reactive import and export.

Metering data provided to us shall be consistent with that received through the metering equipment installed.

- 2.70 Metering data shall be provided in an electronic format specified by us from time to time and in the absence of such specification, metering data shall be provided in a comma-separated text file in the format of Master Registration Agreement (MRA) data flow D0275⁴ (as agreed with us). The data shall be e-mailed to duos.income.billing@sse.com.
- 2.71 We require details of reactive power imported or exported to be provided for all Measurement Class C and E sites. It is also required for CVA sites and Exempt Distribution Network boundaries with difference metering. We reserve the right to levy a charge on Users who fail to provide such reactive data. In order to estimate missing reactive data, a power factor of 0.95 lag will be applied to the active consumption in any half hour.

Out of Area Use of System Charges

- 2.72 We operate embedded distribution networks in the other DNO area in Scotland. The charges for these 'out of area' networks are provided in a separate charging statement. This statement is available from our website www.ssen.co.uk.

Licensed Distributor Network Operator charges

- 2.73 Licensed Distribution Network Operator (LDNO) charges are applied to LDNOs who operate Embedded Networks within our Distribution Services Area.
- 2.74 The charge structure for LV and HV Designated Properties embedded in networks operated by LDNOs will mirror the structure of the "All-the-way" charge and is dependent upon the voltage of connection of each Embedded Network to the Host DNO's network. The relevant charge structures are set out in Annex 4.
- 2.75 Where a NHH metered MPAN has an invalid Settlement combination, the 'LDNO HV: Domestic Aggregated with Residual' fixed and unit charges will be applied as default until the invalid combination is corrected. Where there are multiple SSC/TPR combinations, the default 'LDNO HV: Domestic Aggregated with Residual' fixed and unit charges will be applied for each invalid TPR combination.
- 2.76 The charge structure for Designated EHV Properties embedded in networks operated by LDNOs will be calculated individually using the EDCM. The relevant charge structures are set out in Annex 2.
- 2.77 For Nested Networks the relevant charging principles set out in DCUSA Schedule 21 will apply.

Licence exempt distribution networks

- 2.78 The Electricity and Gas (Internal Market) Regulations 2011⁵ introduced new obligations on owners of licence exempt distribution networks (sometimes called private networks) including a duty to facilitate access to electricity and gas Suppliers for Customers within those networks.
- 2.79 When Customers (both domestic and commercial) are located within a licence exempt distribution network and require the ability to choose their own Supplier this is called 'third party access'. These embedded Customers will require an MPAN so that they can have their electricity supplied by a Supplier of their choice.
- 2.80 Licence exempt distribution networks owners can provide third party access using either full settlement metering or the difference metering approach.

Full settlement metering

- 2.81 This is where a licence exempt distribution network is set up so that each embedded installation has an MPAN and Metering System and therefore all Customers purchase electricity from their chosen Supplier. In this case there are no Settlement Metering Systems at the boundary between the licensed Distribution System and the licence exempt distribution network.

⁴ MRA Data Transfer Catalogue available from <https://dtdc.mrasco.com/>

⁵ The Electricity and Gas (Internal Market) Regulations 2011 available from <http://www.legislation.gov.uk/uksi/2011/2704/contents/made>

2.82 In this approach our DUoS charges may be applied to each MPAN.

Difference metering

2.83 This is where one or more, but not all, Customers on a licence exempt distribution network choose their own Supplier for electricity supply to their premises. Under this approach the Customers requiring third party access on the licence exempt distribution network will have their own MPAN and must have a HH Metering System.

Gross settlement

2.84 Where one of our MPANs (prefixed by the number 17) is embedded within a licence exempt distribution network connected to our Distribution System, and difference metering is in place for Settlement purposes and we receive gross measurement data for the boundary MPAN, we will continue to charge the boundary MPAN Supplier for use of our Distribution System. No charges will be levied by us directly to the Customer or Supplier of the embedded MPAN(s) connected within the licence exempt distribution network.

2.85 We require that gross metered data for the boundary of the connection is provided to us. Until a new industry data flow is introduced for the sending of such gross data, gross metered data shall:

- be provided in a text file in the format of the D0036 or D0275 MRA data flow;
- the text file shall be emailed to duos.income.billing@sse.com;
- the title of the email should also contain the phrase “gross data for difference metered private network” and contain the metering reference specified by us in place of the Settlement MPAN; and
- the text filename shall be formed of the metering reference specified by us followed by a hyphen and followed by a timestamp in the format YYYYMMDDHHMMSS and followed by “.txt”.

2.86 For the avoidance of doubt, the reduced difference metered measurement data for the boundary connection that is to enter Settlement should continue to be sent using the Settlement MPAN.

3. Schedule of Charges for use of the Distribution System

- 3.1 Tables listing the charges for use of our Distribution System are published in annexes to this document.
- 3.2 These charges are also listed in a spreadsheet which is published with this statement and can be downloaded from our website www.ssen.co.uk.
- 3.3 Annex 1 contains the charges applied to LV and HV Designated Properties.
- 3.4 Annex 2 contains the charges applied to Designated EHV Properties and charges applied to LDNOs for Designated EHV Properties connected to their Distribution Systems.
- 3.5 Annex 3 contains details of any preserved and additional charges that are valid at this time. Preserved charges are mapped to an appropriate charge and are closed to new Customers.
- 3.6 Annex 4 contains the charges applied to LDNOs in respect of LV and HV Designated Properties connected to their Distribution Systems.

4. Schedule of Line Loss Factors

Role of Line Loss Factors in the Supply of Electricity

- 4.1 Electricity entering or exiting our Distribution System is adjusted to take account of energy that is lost⁶ as it is distributed through the network. This adjustment does not affect distribution charges but is used in energy settlement to take metered consumption to a notional Grid Supply Point so that Suppliers' purchases take account of the energy lost on the Distribution System.
- 4.2 We are responsible for calculating the Line Loss Factors (LLFs) and providing these to Elexon. Elexon is the company that manages the BSC.
- 4.3 LLFs are used to adjust the Metering System volumes to take account of losses on the Distribution System.

Calculation of Line Loss Factors

- 4.4 LLFs are calculated in accordance with BSCP128 which sets out the procedures and principles with which our LLF methodology must comply. It also defines the procedure and timetable by which LLFs are reviewed and submitted.
- 4.5 LLFs are calculated for a set number of time periods during the year, using either a generic or a site specific method. The generic method is used for sites connected at LV or HV and the site specific method is used for sites connected at EHV or where a request for site specific LLFs has been agreed. Generic LLFs will be applied as a default to all new EHV sites until sufficient data is available for a site specific calculation.

Where the usage profile for a given site contains insufficiently large consumption or generation volumes to enable calculation of realistic Site Specific LLFs then a default calculation, or default replacement process shall be undertaken. The definition of EHV used for LLF purposes differs from the definition used for defining Designated EHV Properties in the EDCM. The definition used for LLF purposes can be found in our LLF methodology which can be found on the Elexon website⁷.

Publication of Line Loss Factor tables

- 4.6 The LLFs used in Settlement are published on the Elexon Portal⁸. The website contains the LLFs in standard industry data formats and in a summary form. A user guide with details on registering and using the portal is also available.
- 4.7 BSCP 128 sets out the timetable by which LLFs are submitted and audited. The submission and audit occurs between September and December in the year prior to the LLFs becoming effective. Only after the completion of the audit at the end of December and BSC approval are the final LLFs published.
- 4.8 At the time that this charging statement is first published, Annex 5 will be intentionally left blank, as this statement is published a complete year before the LLFs have been calculated and audited. Once the final BSCP128 Audit Report has been received, we will issue an updated version of Annex 5 containing the audited LLF values.
- 4.9 When using the tables in Annex 5, reference should be made to the LLFC allocated to the MPAN to find the appropriate values.

⁶ Energy can be lost for technical and non-technical reasons and losses normally occur by heat dissipation through power flowing in conductors and transformers. Losses can also reduce if a Customer's action reduces power flowing in the distribution network. This might happen when a Customer generates electricity and the produced energy is consumed locally.

⁷ The following page has links to BSCP128 and to our LLF methodology: <http://www.elexon.co.uk/reference/technical-operations/losses/>

⁸ The Elexon Portal can be accessed from www.elexonportal.co.uk

5. Notes for Designated EHV Properties

EDCM network group costs

- 5.1 A table is provided in the accompanying spreadsheet which shows the underlying Forward Cost Pricing (FCP) network group costs used to calculate the current EDCM charges. This spreadsheet (SHEPD – Schedule of charges and other tables April 2022_V1.2.xlsx) is available to download from our website www.ssen.co.uk.
- 5.2 These are illustrative of the modelled costs at the time that this statement was published. A new connection will result in changes to current network utilisations which will then form the basis of future prices. The charge determined in this statement will not necessarily be the charge in subsequent years because of the interaction between new and existing network connections and any other changes made to our Distribution System which may affect charges.

Charges for New Designated EHV Properties

- 5.3 Charges for any new Designated EHV Properties calculated after publication of the current statement will be published on our website in an addendum to that statement as and when necessary. The addendum will include charge information of the type found in Annex 2, and LLFs as found in Annex 5.
- 5.4 The form of the addendum is detailed in Annex 6 of this statement.
- 5.5 The new Designated EHV Properties' charges will be added to Annex 2 in the next full statement released.

Charges for Amended Designated EHV Properties

- 5.6 Where an existing Designated EHV Property connection is modified and energised in the charging year, we may revise our EDCM charges for the modified Designated EHV Property. If revised charges are appropriate, an addendum will be sent to all relevant parties and published as a revised 'Schedule of Charges and Other Tables' spreadsheet on our website www.ssen.co.uk. The modified Designated EHV Property charges will be added to Annex 2 in the next full statement released.

Demand Side Management

- 5.7 New or existing Designated EHV Property Customers may wish to offer part of their MIC to be interruptible by us (for active network management purposes other than normal planned or unplanned outages) in order to benefit from any reduced DUoS charges calculated using the EDCM.
- 5.8 Several options exist in which we may agree for some or the entire MIC to be interruptible. Under the EDCM the applicable demand capacity costs would be based on the MIC minus the capacity subject to interruption.
- 5.9 If you are interested in making part or all of your MIC interruptible as an integral irrevocable feature of a new connection or modification to an existing connection you should in the first instance contact our connections function;
connections@ssen.co.uk

You must make an express statement in your application that you have an interest in some or all of the import capacity being interruptible for active network management purposes.

- 5.10 If you are proactively interested in voluntarily but revocably offering to make some or all of your existing connection's MIC interruptible you should in the first instance contact us at the address in paragraph 5.9.

6. Electricity Distribution Rebates

- 6.1 We have neither given nor announced any DUoS rebates to Users in the 12 months preceding the date of publication of this version of the statement.

7. Accounting and Administration Services

- 7.1 Other than the charges noted below, no Accounting and Administration charges are detailed within this statement. Please refer to our Statement of Miscellaneous Charges for details of our transactional charges and other notices.
- 7.2 We reserve the right to impose payment default remedies. The remedies are as set out in the DCUSA where applicable or else as detailed in the following paragraph.
- 7.3 If any invoices that are not subject to a valid dispute remain unpaid on the due date, late payment interest (calculated at Base Rate plus 8%) and administration charges may be imposed.
- 7.4 Our administration charges are detailed in the following table.

Size of Unpaid Debt	Late Payment Fee
Up to £999.99	£40.00
£1,000 to £9,999.99	£70.00
£10,000 or more	£100.00

8. Charges for electrical plant provided ancillary to the grant of Use of System

- 8.1 No charges for electrical plant provided ancillary to the grant of Use of System are detailed within this statement. Please refer to our Statement of Miscellaneous Charges for details of transactional charges and other notices.

9. Schedule of fixed adders to recover Supplier of Last Resort and Eligible Bad Debt pass-through costs

Supplier of Last Resort

- 9.1 In accordance with Standard Condition 38B 'Treatment of payment claims for last-resort supply where Valid Claim is received on or after 1 April 2019' ('SLC38B') of our Electricity Distribution Licence, and subject to paragraph 9 of that condition, our charges will recover the amount of payments in Regulatory Year t-2 made in response to Last Resort Supply Payment claims. In accordance with Charge Restriction Condition 2B 'Calculation of Allowed Pass-Through Items' ('CRC2B'), specifically paragraph 35 of that condition, other relevant adjustments may also be included.

Excess Supplier of Last Resort

- 9.2 In accordance with paragraph 9 of SLC38B, we may amend previously published charges as a result of Last Resort Supply Payment claims which breach the Materiality Threshold.
- 9.3 In such instance, we will include the fixed charge adder to recover these costs separately to the charges calculated in accordance with paragraph 9.1. The Excess Supplier of Last Resort fixed adder therefore represents an increase to previously published charges only.

Eligible Bad Debt

- 9.4 In accordance with CRC2B, specifically paragraph 39 of that condition, our charges will recover the amount of use of system bad debt the Authority has consented to be recovered. This includes use of system bad debt our charges are recovering on behalf of Independent Distribution Network Operators (IDNOs), in accordance with Standard Licence Condition 38C 'Treatment of Valid Bad Debt Claims' ('SLC38C'), and specifically paragraph 4 of that condition, plus any amounts being returned by us, including on behalf of IDNOs.

Tables of Fixed Adders

- 9.5 Tables listing the charges to recover Supplier of Last Resort and Eligible Bad Debt pass-through costs are published in Annex 7 to this document.

10. Non-Final Demand Sites

Charges for Non-Final Demand Sites

- 10.1. A Non-Final Demand Site is charged an import tariff that excludes the residual cost element of charges. If the User wishes for a property to qualify for allocation to these tariffs, then the User must submit certification declaring that the property meets the required criteria as per DCUSA.

Process for submitting certification

- 10.2. This certification should take the form as set out in Appendix 3 and be submitted to Authorised Capacity using the contact details in 1.12.

We may, at our discretion, request a signed paper certificate from the User, in place of electronic. If requested, paper certification should be posted to the contact details in 1.12.

- 10.3. Users should undertake reasonable endeavours to ensure the facts attested to in the certification are true. We may request documentation evidencing these endeavours, including where appropriate, photographs of metering positions or system diagrams, following receipt of the certification.
- 10.4. If we determine that the documentation provided does not sufficiently evidence the undertaking of reasonable endeavours, does not support the facts attested to in the certification, or if no documentation is received, we may at our discretion reject the certification as invalid. If the certification is rejected as invalid, then the property will not qualify as a Non-Final Demand Site.

Application of charges for Non-Final Demand Site

- 10.5. A property will only be deemed to qualify as a Non-Final Demand Site, and be allocated charges as such, from the date on which we receive valid certification.
- 10.6. If a property that has previously been certified as a Non-Final Demand Site no longer satisfies the criteria as per DCUSA, then the User must inform us immediately.
- 10.7. For a property that has been previously certified as a Non-Final Demand Site, we will continue to apply the relevant no residual import tariff without the requirement for further certification, except in any one of the following circumstances;
- (a) Where we have reason to believe that the property no longer qualifies as a Non-Final Demand Site; or,
 - (b) Significant time has passed since the certification was submitted; or,
 - (c) Where there is a change to the connection characteristics i.e. capacity change.

If such circumstances occur, we may request re-certification of the site, or reject the certification as invalid at our discretion.

- 10.8. When a property no longer meets the required criteria to qualify as a Non-Final Demand Site, we will change the allocation of charges accordingly from that point.
- 10.9. Please refer to the section 'Allocation of Charges' if you believe the property has been incorrectly not allocated charges as a Non-Final Demand Site.

Appendix 1 – Glossary

1.1. The following definitions, which can extend to grammatical variations and cognate expressions, are included to aid understanding:

Term	Definition
All-the-way Charge	A charge that is applicable to an end user rather than an LDNO. An end user in this context is a Supplier/User who has a registered MPAN or MSID and is using the Distribution System to transport energy on behalf of a Customer.
Balancing and Settlement Code (BSC)	The BSC contains the governance arrangements for electricity balancing and settlement in Great Britain. An overview document is available from https://www.elexon.co.uk/bsc-and-codes/balancing-settlement-code/
Balancing and Settlement Code Procedure (BSCP)	A document of that title, as established or adopted and from time to time modified by the Panel in accordance with The Code, setting out procedures to be complied with (by Parties, Party Agents, BSC Agents, BSCCo, the Panel and others) in, and other matters relating to, the implementation of The Code;
Common Distribution Charging Methodology (CDCM)	The CDCM used for calculating charges to Designated Properties as required by standard licence condition 13A of the Electricity Distribution Licence.
Connection Agreement	An agreement between an LDNO and a Customer which provides that the Customer has the right for its connected installation to be and remain directly or indirectly connected to that LDNO's Distribution System.
Central Volume Allocation (CVA)	As defined in the BSC.
Customer	A person to whom a User proposes to supply, or for the time being supplies, electricity through an exit point, or from whom, a User or any relevant exempt Supplier, is entitled to recover charges, compensation or an account of profits in respect of electricity supplied through an exit point; or A person from whom a User purchases, or proposes to purchase, electricity, at an entry point (who may from time to time be supplied with electricity as a Customer of that User (or another electricity Supplier) through an exit point).
Designated EHV Properties	As defined in standard condition 13B of the Electricity Distribution Licence.
Designated Properties	As defined in standard condition 13A of the Electricity Distribution Licence.
Distribution Connection and Use of System Agreement (DCUSA)	The DCUSA is a multi-party contract between the licensed electricity distributors, suppliers, generators and Offshore Transmission Owners of Great Britain. It is a requirement that all licensed electricity distributors and suppliers become parties to the DCUSA.

Term	Definition																																																																																	
Distributor IDs	<p>These are unique IDs that can be used, with reference to the MPAN, to identify your LDNO. The charges for other network operators can be found on their website.</p> <table border="1" data-bbox="496 338 1305 1615"> <thead> <tr> <th>ID</th> <th>Distribution Service Area</th> <th>Company</th> </tr> </thead> <tbody> <tr><td>10</td><td>East of England</td><td>UK Power Networks</td></tr> <tr><td>11</td><td>East Midlands</td><td>Western Power Distribution</td></tr> <tr><td>12</td><td>London</td><td>UK Power Networks</td></tr> <tr><td>13</td><td>Merseyside and North Wales</td><td>Scottish Power</td></tr> <tr><td>14</td><td>Midlands</td><td>Western Power Distribution</td></tr> <tr><td>15</td><td>Northern</td><td>Northern Powergrid</td></tr> <tr><td>16</td><td>North Western</td><td>Electricity North West</td></tr> <tr><td>17</td><td>Scottish Hydro Electric (and embedded networks in other areas)</td><td>Scottish Hydro Electric Power Distribution plc</td></tr> <tr><td>18</td><td>South Scotland</td><td>Scottish Power</td></tr> <tr><td>19</td><td>South East England</td><td>UK Power Networks</td></tr> <tr><td>20</td><td>Southern Electric (and embedded networks in other areas)</td><td>Southern Electric Power Distribution plc</td></tr> <tr><td>21</td><td>South Wales</td><td>Western Power Distribution</td></tr> <tr><td>22</td><td>South Western</td><td>Western Power Distribution</td></tr> <tr><td>23</td><td>Yorkshire</td><td>Northern Powergrid</td></tr> <tr><td>24</td><td>All</td><td>Independent Power Networks</td></tr> <tr><td>25</td><td>All</td><td>ESP Electricity</td></tr> <tr><td>26</td><td>All</td><td>Last Mile Electricity Ltd</td></tr> <tr><td>27</td><td>All</td><td>The Electricity Network Company Ltd</td></tr> <tr><td>29</td><td>All</td><td>Harlaxton Energy Networks</td></tr> <tr><td>30</td><td>All</td><td>Peel Electricity Networks Ltd</td></tr> <tr><td>31</td><td>All</td><td>UK Power Distribution Ltd</td></tr> <tr><td>32</td><td>All</td><td>Energy Assets Networks Limited</td></tr> <tr><td>33</td><td>All</td><td>Eclipse Power Networks Ltd</td></tr> <tr><td>34</td><td>All</td><td>Murphy Power Distribution Ltd</td></tr> <tr><td>35</td><td>All</td><td>Fulcrum Electricity Assets Ltd</td></tr> <tr><td>36</td><td>All</td><td>Vattenfall Networks Ltd</td></tr> </tbody> </table>	ID	Distribution Service Area	Company	10	East of England	UK Power Networks	11	East Midlands	Western Power Distribution	12	London	UK Power Networks	13	Merseyside and North Wales	Scottish Power	14	Midlands	Western Power Distribution	15	Northern	Northern Powergrid	16	North Western	Electricity North West	17	Scottish Hydro Electric (and embedded networks in other areas)	Scottish Hydro Electric Power Distribution plc	18	South Scotland	Scottish Power	19	South East England	UK Power Networks	20	Southern Electric (and embedded networks in other areas)	Southern Electric Power Distribution plc	21	South Wales	Western Power Distribution	22	South Western	Western Power Distribution	23	Yorkshire	Northern Powergrid	24	All	Independent Power Networks	25	All	ESP Electricity	26	All	Last Mile Electricity Ltd	27	All	The Electricity Network Company Ltd	29	All	Harlaxton Energy Networks	30	All	Peel Electricity Networks Ltd	31	All	UK Power Distribution Ltd	32	All	Energy Assets Networks Limited	33	All	Eclipse Power Networks Ltd	34	All	Murphy Power Distribution Ltd	35	All	Fulcrum Electricity Assets Ltd	36	All	Vattenfall Networks Ltd
ID	Distribution Service Area	Company																																																																																
10	East of England	UK Power Networks																																																																																
11	East Midlands	Western Power Distribution																																																																																
12	London	UK Power Networks																																																																																
13	Merseyside and North Wales	Scottish Power																																																																																
14	Midlands	Western Power Distribution																																																																																
15	Northern	Northern Powergrid																																																																																
16	North Western	Electricity North West																																																																																
17	Scottish Hydro Electric (and embedded networks in other areas)	Scottish Hydro Electric Power Distribution plc																																																																																
18	South Scotland	Scottish Power																																																																																
19	South East England	UK Power Networks																																																																																
20	Southern Electric (and embedded networks in other areas)	Southern Electric Power Distribution plc																																																																																
21	South Wales	Western Power Distribution																																																																																
22	South Western	Western Power Distribution																																																																																
23	Yorkshire	Northern Powergrid																																																																																
24	All	Independent Power Networks																																																																																
25	All	ESP Electricity																																																																																
26	All	Last Mile Electricity Ltd																																																																																
27	All	The Electricity Network Company Ltd																																																																																
29	All	Harlaxton Energy Networks																																																																																
30	All	Peel Electricity Networks Ltd																																																																																
31	All	UK Power Distribution Ltd																																																																																
32	All	Energy Assets Networks Limited																																																																																
33	All	Eclipse Power Networks Ltd																																																																																
34	All	Murphy Power Distribution Ltd																																																																																
35	All	Fulcrum Electricity Assets Ltd																																																																																
36	All	Vattenfall Networks Ltd																																																																																
Distribution Network Operator (DNO)	An electricity distributor that operates one of the 14 distribution services areas and in whose Electricity Distribution Licence the requirements of Section B of the standard conditions of that licence have effect.																																																																																	
Distribution Services Area	The area specified by the Gas and Electricity Markets Authority within which each DNO must provide specified distribution services.																																																																																	

Term	Definition
Distribution System	<p>The system consisting (wholly or mainly) of electric lines owned or operated by an authorised distributor that is used for the distribution of electricity from:</p> <ul style="list-style-type: none"> • Grid Supply Points or generation sets or other entry points <p>to the points of delivery to:</p> <ul style="list-style-type: none"> • Customers or Users or any transmission licensee in its capacity as operator of that licensee’s transmission system or the Great Britain (GB) transmission system and includes any remote transmission assets (owned by a transmission licensee within Scotland) <p>that are operated by that authorised distributor and any electrical plant, electricity meters, and metering equipment owned or operated by it in connection with the distribution of electricity, but does not include any part of the GB transmission system.</p>
EHV Distribution Charging Methodology (EDCM)	The EDCM used for calculating charges to Designated EHV Properties as required by standard licence condition 13B of the Electricity Distribution Licence.
Electricity Distribution Licence	The Electricity Distribution Licence granted or treated as granted pursuant to section 6(1) of the Electricity Act 1989.
Electricity Distributor	Any person who is authorised by an Electricity Distribution Licence to distribute electricity.
Embedded Network	An electricity Distribution System operated by an LDNO and embedded within another Distribution System.
Engineering Recommendation P2/7	A document of the Energy Networks Association, which defines minimum planning standards for security of supply and is referred to in Standard Licence Condition 24 of our Electricity Distribution Licence.
Entry Point	A boundary point at which electricity is exported onto a Distribution System from a connected installation or from another Distribution System, not forming part of the total system (boundary point and total system having the meaning given to those terms in the BSC).
Exit Point	A point of connection at which a supply of electricity may flow from the Distribution System to the Customer’s installation or User’s installation or the Distribution System of another person.
Extra-High Voltage (EHV)	Nominal voltages of 22kV and above.
Final Demand Site	As defined in DCUSA Schedule 32
Gas and Electricity Markets Authority (GEMA)	As established by the Utilities Act 2000.
Grid Supply Point (GSP)	A metered connection between the electricity transmission system and the licensee’s Distribution System at which electricity flows to or from the Distribution System.
GSP group	A distinct electrical system that is supplied from one or more GSPs for which total supply into the GSP group can be determined for each half hour.

Term	Definition
High Voltage (HV)	Nominal voltages of at least 1kV and less than 22kV.
Intermittent Generation	Defined in DCUSA Schedule 16 as a generation plant where the energy source of the prime mover can not be made available on demand, in accordance to the definitions in Engineering Recommendation P2/7.
Invalid Settlement Combination	A Settlement combination that is not recognised as a valid combination in market domain data - see https://www.elexonportal.co.uk/MDDVIEWER .
kVA	Kilovolt ampere.
kVArh	Kilovolt ampere reactive hour.
kW	Kilowatt.
kWh	Kilowatt hour (equivalent to one "unit" of electricity).
Licensed Distribution Network Operator (LDNO)	The holder of a Licence to distribute electricity.
Line Loss Factor (LLF)	The factor that is used in Settlement to adjust the metering system volumes to take account of losses on the Distribution System.
Line Loss Factor Class (LLFC)	An identifier assigned to an SVA metering system which is used to assign the LLF and use of system charges.
Load Factor	$= \frac{\text{annual consumption (kWh)}}{\text{maximum demand (kW)} \times \text{hours in year}}$
Low Voltage (LV)	Nominal voltages below 1kV.
Market Domain Data (MDD)	MDD is a central repository of reference data available to all Users involved in Settlement. It is essential to the operation of SVA trading arrangements.
Maximum Export Capacity (MEC)	The MEC of apparent power expressed in kVA that has been agreed can flow through the entry point to the Distribution System from the Customer's installation as specified in the connection agreement.
Maximum Import Capacity (MIC)	The MIC of apparent power expressed in kVA that has been agreed can flow through the exit point from the Distribution System to the Customer's installation as specified in the connection agreement.

Term	Definition
Measurement Class	<p>A classification of Metering Systems used in the BSC which indicates how consumption is measured, i.e.:</p> <ul style="list-style-type: none"> • Measurement Class A – non-half-hourly metering equipment; • Measurement Class B – non-half-hourly unmetered supplies; • Measurement Class C – half-hourly metering equipment at or above 100kW premises; • Measurement Class D – half-hourly unmetered supplies; • Measurement Class E – half-hourly metering equipment below 100kW premises, and from 5 November 2015, with current transformer; • Measurement Class F – half hourly metering equipment at below 100kW premises with current transformer or whole current, and at domestic premises; and • Measurement Class G – half hourly metering equipment at below 100kW premises with whole current and not at domestic premises.
Meter Timeswitch Code (MTC)	<p>MTCs are three digit codes allowing Suppliers to identify the metering installed in Customers' premises. They indicate whether the meter is single or multi-rate, pre-payment or credit, or whether it is 'related' to another meter. Further information can be found in MDD.</p>
Metering Point	<p>The point at which electricity that is exported to or imported from the licensee's Distribution System is measured, is deemed to be measured, or is intended to be measured and which is registered pursuant to the provisions of the MRA. For the purposes of this statement, GSPs are not 'Metering Points'.</p>
Metering Point Administration Number (MPAN)	<p>A number relating to a Metering Point under the MRA.</p>
Metering System	<p>Particular commissioned metering equipment installed for the purposes of measuring the quantities of exports and/or imports at the exit point or entry point.</p>
Metering System Identifier (MSID)	<p>MSID is a term used throughout the BSC and its subsidiary documents and has the same meaning as MPAN as used under the MRA.</p>
Master Registration Agreement (MRA)	<p>The Master Registration Agreement (MRA) provides a governance mechanism to manage the processes established between electricity suppliers and distribution companies to enable electricity suppliers to transfer customers. It includes terms for the provision of Metering Point Administration Services (MPAS) Registrations. The MRA was superseded by the Retail Energy Code (REC) on 1st September 2021.</p>
Nested Networks	<p>This refers to a situation where there is more than one level of Embedded Network and therefore nested Distribution Systems between LDNOs (e.g. host DNO ← primary nested DNO ← secondary nested DNO ← Customer).</p>
Non-Final Demand Site	<p>As defined in DCUSA Schedule 32.</p>
Non-Intermittent Generation	<p>Defined in DCUSA Schedule 16 as a generation plant where the energy source of the prime mover can be made available on demand, in accordance to the definitions in Engineering Recommendation P2/7.</p>
Ofgem	<p>Office of Gas and Electricity Markets – Ofgem is governed by GEMA and is responsible for the regulation of the distribution companies.</p>

Term	Definition
Profile Class (PC)	A categorisation applied to NHH MPANs and used in settlement to group Customers with similar consumption patterns to enable the calculation of consumption profiles.
Retail Energy Code (REC)	This consolidates existing retail provisions, as set out in the Master Registration Agreement (MRA) and Supply Point Administration Agreement (SPAA).
Settlement	The determination and settlement of amounts payable in respect of charges (including reconciling charges) in accordance with the BSC.
Settlement Class (SC)	The combination of Profile Class, Line Loss Factor Class, Time Pattern Regime and Standard Settlement Configuration, by Supplier within a GSP group and used for Settlement.
Standard Settlement Configuration (SSC)	A standard metering configuration relating to a specific combination of Time Pattern Regimes.
Supercustomer	The method of billing Users for use of system on an aggregated basis, grouping together consumption and standing charges for all similar NHH metered Customers or aggregated HH metered Customers.
Supercustomer DUoS Report	A report of profiled data by Settlement Class providing counts of MPANs and units consumed.
Supplier	An organisation with a supply licence responsible for electricity supplied to and/or exported from a Metering Point.
Supplier Volume Allocation (SVA)	As defined in the BSC.
Time Pattern Regime (TPR)	The pattern of switching behaviour through time that one or more meter registers follow.
Unmetered Supplies	Exit points deemed to be suitable as unmetered supplies as permitted in the Electricity (Unmetered Supply) Regulations 2001 and where operated in accordance with BSC procedure 520 ⁹ .
Use of System Charges	Charges which are applicable to those parties which use the Distribution System.
User	Someone that has a use of system agreement with the DNO e.g. a Supplier, generator or other LDNO.

⁹ Balancing and Settlement Code Procedures are available from <http://www.elexon.co.uk/pages/bscps.aspx>

Appendix 2 - Guidance notes¹⁰

Background

- 1.1. The electricity bill from your Supplier contains an element of charge to cover electricity distribution costs. This distribution charge covers the cost of operating and maintaining a safe and reliable Distribution System that forms the 'wires' that transport electricity between the national transmission system and end users such as homes and businesses. Our Distribution System includes overhead lines, underground cables, as well as substations and transformers.
- 1.2. In most cases, your Supplier is invoiced for the distribution charge and this is normally part of your total bill. In some cases, for example business users, the Supplier may pass through the distribution charge as an identifiable line item on the electricity bill.
- 1.3. Where electricity is generated at a premises your Supplier may receive a credit for energy that is exported on to the Distribution System. These credits are intended to reflect that the exported generation may reduce the need for traditional demand led reinforcement of the Distribution System.
- 1.4. Understanding your distribution charges could help you reduce your costs and increase your credits. This is achieved by understanding the components of the charge to help you identify whether there may be opportunities to change the way you use the Distribution System.

Meter point administration

- 1.5. We are responsible for managing the electricity supply points that are connected to our Distribution System. Typically every supply point is identified by a Meter Point Administration Number (MPAN). A few supply points may have more than one MPAN depending on the metering configuration (e.g. a school which may have an MPAN for the main supply and an MPAN for catering).
- 1.6. The full MPAN is a 21 digit number, preceded by an 'S' and includes supplementary data. The MPAN applicable to a supply point is found on the electricity bill from your Supplier. This number enables you to establish who your electricity distributor is, details of the characteristics of the supply and importantly the distribution charges that are applicable to your premises.
- 1.7. The 21-digit number is normally presented in two sections as shown in the following diagram. The top section is supplementary data which gives information about the characteristics of supply, while the bottom 'core' is the unique identifier.

Full MPAN diagram

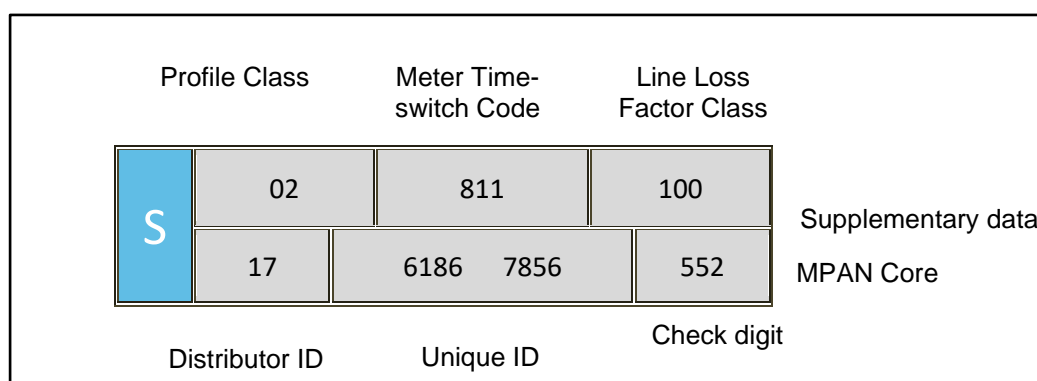

- 1.8. Generally, you will only need to know the Distributor ID and LLFC to identify the distribution charges for your premises. However, there are some premises where charges are specific to that site. In these instances the charges are identified by the MPAN core. The Distributor ID for SHEPD is 17. Other Distributor IDs can be referenced in the Glossary.

¹⁰ These guidance notes are provided for additional information and do not form part of the application of charges.

- 1.9. Additionally it can be useful to understand the profile class provided in the supplementary data. The profile class will be a number between 00 and 08. The following list provides details of the allocation of profile classes to types of Customers:
- '01' – Domestic Customers with unrestricted supply
 - '02' – Domestic Customers with restricted load, for example off-peak heating
 - '03' – Non-domestic Customers with unrestricted supply
 - '04' – Non-domestic Customers with restricted load, for example off-peak heating
 - '05' – Non-domestic maximum demand Customers with a Load Factor of less than 20%
 - '06' – Non-domestic maximum demand Customers with a Load Factor between 20% and 30%
 - '07' – Non-domestic maximum demand Customers with a Load Factor between 30% and 40%
 - '08' – Non-domestic maximum demand Customers with a Load Factor over 40% or non-half-hourly metered generation Customers
 - '00' – Half-hourly metered demand and generation Customers
- 1.10. Unmetered Supplies will be allocated to profile class 01, 08 or 00 depending on the type of load or the measurement method of the load.
- 1.11. The allocation of the profile class will affect your charges. If you feel that you have been allocated the wrong profile class, please contact your Supplier as they are responsible for this.

Your charges

- 1.12. All distribution charges that relate to our Distributor ID 17 and to premises within our Distribution Services Area are provided in this statement. For distribution charges which relate to our Distributor ID 17 and to premises connected to an 'out of area' network, please refer to the statement referenced in paragraph 2.72.
- 1.13. You can identify your charges by referencing your LLFC, from Annex 1. If the MPAN is for a Designated EHV Property then the charges will be found in Annex 2. In a few instances, the charges may be contained in Annex 3 or Annex 6. When identifying charges in Annex 2, please note that some LLFCs have more than one charge. In this instance you will need to select the correct charge by cross referencing with the MPAN core provided in the table.
- 1.14. Once you have identified which charge structure applies to your MPAN then you will be able to calculate an estimate of your distribution charge using the calculator provided in the spreadsheet 'Schedule of charges and other tables' found in the sheet called 'Charge Calculator'. This spreadsheet can be downloaded from www.ssen.co.uk.

Reducing your charges

- 1.15. The most effective way to reduce your energy charges is to reduce your consumption by switching off or using more energy efficient appliances. However, there are also other potential opportunities to reduce your distribution charges; for example, it may be beneficial to shift demand or generation to a better time period. Demand use is likely to be cheaper outside the peak periods and generation credits more beneficial during peak periods, although the ability to directly benefit will be linked to the structure of your supply charges.
- 1.16. The calculator mentioned above provides the opportunity to establish a forecast of the change in distribution charges that could be achieved if you are able to change any of the consumption related inputs.

Reactive power and reactive power charges

- 1.17. Reactive power is a separately charged component of connections that are half-hourly metered. Reactive power charges are generally avoidable if 'best practice' design of the properties' electrical installation has been provided in order to maintain a power factor between 0.95 and unity at the Metering Point.

- 1.18. Reactive Power (kVArh) is the difference between working power (active power measured in kW) and total power consumed (apparent power measured in kVA). Essentially it is a measure of how efficiently electrical power is transported through an electrical installation or a Distribution System.
- 1.19. Power flowing with a power factor of unity results in the most efficient loading of the Distribution System. Power flowing with a power factor of less than 0.95 results in much higher losses in the Distribution System, a need to potentially provide higher capacity electrical equipment and consequently a higher bill for you the consumer. A comparatively small improvement in power factor can bring about a significant reduction in losses since losses are proportional to the square of the current.
- 1.20. Different types of electrical equipment require some 'reactive power' in addition to 'active power' in order to work effectively. Electric motors, transformers and fluorescent lighting, for example, may produce poor power factors due to the nature of their inductive load. However, if good design practice is applied then the poor power factor of appliances can be corrected as near as possible to source. Alternatively poor power factor can be corrected centrally near to the meter.
- 1.21. There are many advantages that can be achieved by correcting poor power factor. These include: reduced energy bills through lower reactive charges, lower capacity charges and reduced power consumption and reduced voltage drop in long cable runs.

Site-specific EDCM charges

- 1.22. A site classified as a Designated EHV Property is subject to a locational based charging methodology (referred to as EDCM) for higher voltage network users. Distributors use one of two approved approaches; Long Run Incremental Cost (LRIC) or Forward Cost Pricing (FCP); we use the FCP. The EDCM will apply to Customers connected at Extra-High Voltage or connected at High Voltage and metered at a high voltage substation.
- 1.23. EDCM charges and credits are site-specific, reflecting the degree to which the local and higher voltage networks have the capacity to serve more demand without the need to upgrade the electricity infrastructure. The conditions for eligibility of generators for credits within the EDCM are specified in the applicable charging methodology. Generators that benefit from an exemption from UoS charges for generation, or that are intermittent in accordance to the definitions in Engineering Recommendation P2/7 and that cannot maintain production for a continuous period of several weeks, are unlikely to be eligible for EDCM credits. In any event, eligibility for EDCM credits depends on a site-specific assessment of whether the generation can be considered to have a contribution to security of supply under Engineering Recommendation P2/7.
- 1.24. The charges under the EDCM comprise of the following individual components:
 - a) **Fixed charge (pence/MPAN/day)** - This charge recovers operational costs associated with those connection assets that are provided for the 'sole' use of the Customer. The value of these assets is used as a basis to derive the charge.
 - b) **Capacity charge (pence/kVA/day)** - This charge comprises the relevant FCP component, the National Grid Electricity Transmission cost and other regulated costs.

Capacity charges are levied on the MIC, MEC, and any exceeded capacity. You may wish to review your MIC or MEC periodically to ensure it remains appropriate for your needs as you may be paying for more capacity than you require. If you wish to make changes contact us via the details in paragraph 1.12.

The FCP cost is locational and reflects our assessment of future network reinforcement necessary at the voltage of connection (local) and beyond at all higher voltages (remote) relevant to the Customer's connection. This results in the allocation of higher costs, in more capacity congested parts of the network reflecting the greater likelihood of future reinforcement in these areas and the allocation of lower costs in less congested parts of the network. The local FCP cost is included in the capacity charge.

Our regulated costs include direct and indirect operational costs and a residual amount to ensure recovery of our regulated allowed revenue. The capacity charge recovers these costs using the Customer usage profile and the relevant assets being used to transport electricity between the source substation and Customer's Metering Point.

- c) **Super-red unit charge (pence/kWh)** - This charge recovers the remote FCP component. The charge is positive for import and negative for export which means you can either reduce your charges by minimising consumption or increasing export at those times. The charge is applied to consumption during the Super-red time period as detailed in Annex 2.
- 1.25. Future charge rates may be affected by consumption during the Super-red time period, therefore reducing consumption in the Super-red time period may be beneficial.
- 1.26. **Reactive Power** - The EDCM does not include a separate charge component for any reactive power flows (kVAr) for either demand or generation. However, the EDCM charges do reflect the effect on the network of the Customer's power factor, for example, unit charges can increase if your site power factor is poor (lower than 0.95). Improving your site's power factor will also reduce the maximum demand (kVA) for the same power consumed in kW thus providing scope to reduce your agreed capacity requirements.

Additional Notes

Domestic Aggregated (Related MPAN) and Non-Domestic Aggregated (Related MPAN) are supplementary, off-peak, tariffs to their standard, Domestic Aggregated and Non-Domestic Aggregated tariffs, respectively. Related MPAN, off-peak, terms are only available to Metering Points that are already on such terms and where:

- a) the Customer retains the original off-peak equipment and the circuits from which the off-peak supply is taken are separated from all other circuits;
- b) the function of the off-peak equipment is not duplicated by other equipment connected to the other circuits; and
- c) “off-peak equipment” means appliances such as thermal storage heaters, storage water heaters or other equipment as agreed by SHEPD

Generally, Domestic DUoS tariffs are available only to premises:

- a) used exclusively as a single private residence; or
- b) comprising more than one private residence where the estimated maximum demand of the supply does not exceed 25 kW

Appendix 3 – Non-Final Demand Site Certificate

A certificate set out in the form of the example shown below should be submitted to confirm that a site qualifies as a Non-Final Demand Site.

Non-Final Demand Site Certificate of Compliance

This is to certify that the Metering System listed below qualifies as compliant with the criteria of a Non-Final Demand Site, for the purposes of Use of System charges, and that:

The property is a Single Site at which either or both Electricity Storage and/or Electricity Generation occurs (whether the facility(ies) at the site are operating or being commissioned, repaired, or decommissioned), and that:

- a) has an export MPAN and an import MPAN with associated metering equipment which only measures export from Electricity Storage and/or Electricity Generation and import for or directly relating to Electricity Storage and/or Electricity Generation (and not export from another source and/or import for another activity; and
 - if registered in an MPAS Registration System, is subject to certification from a Supplier Party that the site meets the criteria in paragraph (a) above, which certificate has been provided to the DNO/IDNO Party; or
 - if registered in CMRS, is subject to certification from the Customer (or its CVA Registrant) that the site meets the criteria in paragraph (a) above, which certificate has been provided to the DNO/IDNO Party.

For the purposes of this declaration, the term Non-Final Demand Site has the meaning given to it in the DCUSA.

Metering System Site Address:

Qualifying Import MPAN/MSID(s)

Qualifying Export MPAN/MSID(s)

I declare that I understand the qualification requirements and certify that the above Metering System meets the criteria of a Non-Final Demand Site.

Authorised signatory:

Name and designation:

On behalf of company:

Date:

Annex 1 - Schedule of Charges for use of the Distribution System by LV and HV Designated Properties

Scottish Hydro Electric Power Distribution plc - Effective from 1st April 2022 - Final LV and HV charges

Time Bands for Half Hourly Metered Properties			
Time periods	Red Time Band	Amber Time Band	Green Time Band
Monday to Friday (Including Bank Holidays) All Year	16:00 - 19:00		
Monday to Friday (Including Bank Holidays) All Year		07:00 - 16:00 19:00 - 21:00	
Monday to Friday (Including Bank Holidays) All Year			00:00 - 07:00 21:00 - 24:00
Saturday and Sunday All Year		12:00 - 20:00	00:00 - 12:00 20:00 - 24:00
Notes	All the above times are in UK Clock time		

Time Bands for Half Hourly Unmetered Properties			
	Black Time Band	Yellow Time Band	Green Time Band
Monday to Friday (Including Bank Holidays) March to October		07:00 - 21:00	
Monday to Friday (Including Bank Holidays) November to February	16:00 - 19:00	07:00 - 16:00 19:00 - 21:00	
Monday to Friday (Including Bank Holidays) April to March			00:00 - 07:00 21:00 - 24:00
Saturday and Sunday All Year		12:00 - 20:00	00:00 - 12:00 20:00 - 24:00
Notes	All the above times are in UK Clock time		

Tariff name	Open LLFCs	PCs	Red/black unit charge p/kWh	Amber/yellow unit charge p/kWh	Green unit charge p/kWh	Fixed charge p/MPAN/day	Capacity charge p/kVA/day	Exceeded capacity charge p/kVA/day	Reactive power charge p/kVArh	Closed LLFCs
Domestic Aggregated with Residual	15, 18, 25, 27, 100-101, 105-106, 110-111, 120-121, 125-128, 300-301, 305, 320-321, 325, 506	0, 1, 2	8.758	1.821	0.634	27.51				
Domestic Aggregated (Related MPAN)	16, 19, 26, 28, 102, 122, 302, 322	2	8.758	1.821	0.634					17, 20, 104, 124, 304, 324

Tariff name	Open LLFCs	PCs	Red/black unit charge p/kWh	Amber/yellow unit charge p/kWh	Green unit charge p/kWh	Fixed charge p/MPAN/day	Capacity charge p/kVA/day	Exceeded capacity charge p/kVA/day	Reactive power charge p/kVArh	Closed LLFCs
Non-Domestic Aggregated No Residual	P60, P65, P70, P00, R35, R40, P05, P10, P15, P20, P25, P30, P35, P40, R45, P45, P50, P55, R50, P75, R55, R60, R65, R70, R75, R80, R85, R90, R95, S05, S10	0, 3, 4, 5-8	10.050	2.089	0.727	10.37				S00, S15, S20
Non-Domestic Aggregated Band 1	P61, P66, P71, P01, R36, R41, P06, P11, P16, P21, P26, P31, P36, P41, R46, P46, P51, P56, R51, P76, R56, R61, R66, R71, R76, R81, R86, R91, R96, S06, S11	0, 3, 4, 5-8	10.050	2.089	0.727	13.38				S01, S16, S21
Non-Domestic Aggregated Band 2	P62, P67, P72, P02, R37, R42, P07, P12, P17, P22, P27, P32, P37, P42, R47, P47, P52, P57, R52, P77, R57, R62, R67, R72, R77, R82, R87, R92, R97, S07, S12	0, 3, 4, 5-8	10.050	2.089	0.727	28.17				S02, S17, S22
Non-Domestic Aggregated Band 3	P63, P68, P73, P03, R38, R43, P08, P13, P18, P23, P28, P33, P38, P43, R48, P48, P53, P58, R53, P78, R58, R63, R68, R73, R78, R83, R88, R93, R98, S08, S13	0, 3, 4, 5-8	10.050	2.089	0.727	54.30				S03, S18, S23

Tariff name	Open LLFCs	PCs	Red/black unit charge p/kWh	Amber/yellow unit charge p/kWh	Green unit charge p/kWh	Fixed charge p/MPAN/day	Capacity charge p/kVA/day	Exceeded capacity charge p/kVA/day	Reactive power charge p/kVArh	Closed LLFCs
Non-Domestic Aggregated Band 4	P64, P69, P74, P04, R39, R44, P09, P14, P19, P24, P29, P34, P39, P44, R49, P49, P54, P59, R54, P79, R59, R64, R69, R74, R79, R84, R89, R94, R99, S09, S14	0, 3, 4, 5-8	10.050	2.089	0.727	154.10				S04, S19, S24
Non-Domestic Aggregated (related MPAN)	22, 24, 30, 152, 172, 352, 372	4	10.050	2.089	0.727					155, 175, 355, 375
LV Site Specific No Residual	P80, 31	0	7.244	1.466	0.514	27.17	5.45	9.52	0.290	
LV Site Specific Band 1	P81	0	7.244	1.466	0.514	253.33	5.45	9.52	0.290	
LV Site Specific Band 2	P82	0	7.244	1.466	0.514	453.03	5.45	9.52	0.290	
LV Site Specific Band 3	P83	0	7.244	1.466	0.514	736.93	5.45	9.52	0.290	
LV Site Specific Band 4	P84	0	7.244	1.466	0.514	1686.66	5.45	9.52	0.290	
LV Sub Site Specific No Residual	P85, 32	0	3.745	0.678	0.246	63.83	8.63	11.68	0.137	
LV Sub Site Specific Band 1	P86	0	3.745	0.678	0.246	289.99	8.63	11.68	0.137	
LV Sub Site Specific Band 2	P87	0	3.745	0.678	0.246	489.68	8.63	11.68	0.137	
LV Sub Site Specific Band 3	P88	0	3.745	0.678	0.246	773.58	8.63	11.68	0.137	
LV Sub Site Specific Band 4	P89	0	3.745	0.678	0.246	1723.31	8.63	11.68	0.137	
HV Site Specific No Residual	P90, 604	0	2.620	0.455	0.176	322.11	11.66	13.57	0.093	
HV Site Specific Band 1	P91	0	2.620	0.455	0.176	741.62	11.66	13.57	0.093	

Tariff name	Open LLFCs	PCs	Red/black unit charge p/kWh	Amber/yellow unit charge p/kWh	Green unit charge p/kWh	Fixed charge p/MPAN/day	Capacity charge p/kVA/day	Exceeded capacity charge p/kVA/day	Reactive power charge p/kVAh	Closed LLFCs
HV Site Specific Band 2	P92	0	2.620	0.455	0.176	3586.67	11.66	13.57	0.093	
HV Site Specific Band 3	P93	0	2.620	0.455	0.176	7343.92	11.66	13.57	0.093	
HV Site Specific Band 4	P94	0	2.620	0.455	0.176	15742.67	11.66	13.57	0.093	
Unmetered Supplies	800-805	0, 1 or 8	17.414	4.890	3.923					
LV Generation Aggregated	951	0 or 8	-6.770	-1.407	-0.490	0.00				
LV Sub Generation Aggregated	952	0 or 8	-6.063	-1.246	-0.435	0.00				
LV Generation Site Specific	1-2, 909	0	-6.770	-1.407	-0.490	0.00			0.284	
LV Generation Site Specific no RP charge	9-10	0	-6.770	-1.407	-0.490	0.00				
LV Sub Generation Site Specific	3-4	0	-6.063	-1.246	-0.435	0.00			0.238	
LV Sub Generation Site Specific no RP charge	11-12	0	-6.063	-1.246	-0.435	0.00				
HV Generation Site Specific	5-6, 910	0	-3.399	-0.615	-0.224	526.70			0.216	
HV Generation Site Specific no RP charge	13-14	0	-3.399	-0.615	-0.224	526.70				

Annex 2 - Schedule of Charges for use of the Distribution System by Designated EHV Properties (including LDNOs with Designated EHV Properties/end-users)

Note: The list of MPANs / MSIDs provided may be incomplete; the DNO reserves the right to apply the listed charges to any other MPANs / MSIDs associated with the site.

Scottish Hydro Electric Power Distribution plc - Effective from 1st April 2022 - Final EDCM charges

Time Periods for Designated EHV Properties

Time periods	Super Red Time Band
Monday to Friday (Including Bank Holidays) November to February	16:00 - 19:00
Notes	All the above times are in UK Clock time

Import LLFC	Import MPANs/MSIDs	Export LLFC	Export MPANs/MSIDs	Tariff	Import Super Red unit charge (p/kWh)	Import fixed charge (p/day)	Import capacity charge (p/kVA/day)	Import exceeded capacity charge (p/kVA/day)	Export Super Red unit charge (p/kWh)	Export fixed charge (p/day)	Export capacity charge (p/kVA/day)	Export exceeded capacity charge (p/kVA/day)
595	1712385815400			Tariff 001	0.000	13185.53	6.13	6.13	0.000	0.00	0.00	0.00
596	1700051251844			Tariff 002	0.000	2957.87	2.42	2.42	0.000	0.00	0.00	0.00
597	1711602345053			Tariff 003	0.000	2660.19	7.96	7.96	0.000	0.00	0.00	0.00
598	1717121416604	530	1700052708460	Tariff 004	0.000	2483.38	0.96	0.96	0.000	176.81	0.05	0.05
560	1700051737559	520	1700051732541	Tariff 005	0.000	2.57	0.94	0.94	0.000	308.26	0.05	0.05
560	1700051737568	520	1700051732550	Tariff 006	0.000	3.91	0.94	0.94	0.000	306.92	0.05	0.05
562	1700051741068	522	1700051734177	Tariff 008	0.000	100.37	0.94	0.94	0.000	210.45	0.05	0.05
562	1700051740988	522	1700051737372	Tariff 009	0.000	83.82	0.94	0.94	0.000	227.01	0.05	0.05
562	1700051740960	522	1700051734121	Tariff 010	0.000	9.28	0.94	0.94	0.000	301.55	0.05	0.05
563	1700051737647	523	1700051733944	Tariff 011	0.000	151.02	0.94	0.94	0.000	159.81	0.05	0.05

Import LLFC	Import MPANs/MSIDs	Export LLFC	Export MPANs/MSIDs	Tariff	Import Super Red unit charge (p/kWh)	Import fixed charge (p/day)	Import capacity charge (p/kVA/day)	Import exceeded capacity charge (p/kVA/day)	Export Super Red unit charge (p/kWh)	Export fixed charge (p/day)	Export capacity charge (p/kVA/day)	Export exceeded capacity charge (p/kVA/day)
564	1700051765732	524	1700051765723	Tariff 012	0.000	618.44	0.65	0.65	0.000	0.00	0.00	0.00
565	1721843065002	525	1700051732268	Tariff 013	0.000	102.16	1.35	1.35	0.000	0.00	0.00	0.00
566	1700051741110	526	1700051730386	Tariff 014	0.000	0.00	1.00	1.00	0.000	0.00	0.05	0.05
567	1700052157576	527	1700052157585	Tariff 015	1.784	0.88	5.65	5.65	0.000	0.00	0.00	0.00
569	1710056910505			Tariff 016	0.000	2660.19	11.91	11.91	0.000	0.00	0.00	0.00
713	1712380671009	913	1700051748160	Tariff 017	0.000	2.65	0.38	0.38	0.000	0.00	0.00	0.00
714	1712398153703	914	1700051731539	Tariff 018	0.000	8804.55	0.46	0.46	0.000	2907.78	0.05	0.05
	1700051612511	915	1700051731548	Tariff 019	0.000	0.00	0.00	0.00	0.000	5358.62	0.05	0.05
8707	8707	8707	8707	Tariff 020	0.000	0.33	1.52	1.52	0.000	0.00	0.00	0.00
717	1700051126888	917	1700051731282	Tariff 021	0.000	23.23	0.65	0.65	0.000	669.21	0.05	0.05
718	1700051955969	918	1700051955940	Tariff 022	0.000	17.17	0.83	0.83	0.000	0.00	0.00	0.00
637	1700051778208	837	1700051771578	Tariff 023	0.000	6.32	0.95	0.95	0.000	0.00	0.00	0.00
8328	8328	8328	8328	Tariff 024	0.000	34.29	1.31	1.31	0.000	15775.28	0.05	0.05
722	1700051742780	922	1700051732133	Tariff 025	0.000	2.36	1.70	1.70	0.000	0.00	0.00	0.00
8696	8696	8696	8696	Tariff 026	0.000	2.92	1.59	1.59	0.000	0.00	0.00	0.00
723	1700051976550	923	1700051976560	Tariff 027	0.000	3.94	0.66	0.66	0.000	0.00	0.00	0.00
724	1700052029865	924	1700052029856	Tariff 028	0.000	4.55	0.76	0.76	0.000	0.00	0.00	0.00
725	1700051728590	925	1700051780216	Tariff 029	0.000	44.95	0.57	0.57	0.000	0.00	0.00	0.00
726	1700051703898	926	1700051822559	Tariff 030	0.000	4.96	0.67	0.67	0.000	0.00	0.00	0.00
8699	8699	8699	8699	Tariff 031	0.000	80.87	0.68	0.68	0.000	0.00	0.00	0.00
8699	8699	8699	8699	Tariff 032	0.000	80.87	0.68	0.68	0.000	0.00	0.00	0.00
727	1700051782729	927	1700051782710	Tariff 033	0.000	3.52	0.85	0.85	0.000	0.00	0.00	0.00
730	1700051741990	930	1700051732286	Tariff 035	0.000	5.11	1.26	1.26	0.000	0.00	0.00	0.00
731	1700051584955	931	1700051732374	Tariff 036	0.000	6.37	1.00	1.00	0.000	0.00	0.00	0.00
732	1700052249980	932	1700052249999	Tariff 037	0.000	6.78	0.71	0.71	0.000	1626.59	0.05	0.05
787	1700051754020	987	1700051754011	Tariff 038	0.000	13.32	0.49	0.49	0.000	0.00	0.00	0.00
8688	8688	8688	8688	Tariff 039	0.000	0.92	0.65	0.65	0.000	533.42	0.05	0.05
735	1700051754369	935	1700051775660	Tariff 040	0.000	3.39	0.78	0.78	0.000	0.00	0.00	0.00
736	1700051754401	936	1700051775670	Tariff 041	0.000	3.39	0.83	0.83	0.000	0.00	0.00	0.00
737	1700051742034	937	1700051732310	Tariff 042	0.000	4.61	1.06	1.06	0.000	0.00	0.00	0.00
738	1700051741077	938	1700051734195	Tariff 043	0.000	22.18	0.65	0.65	0.000	665.47	0.05	0.05

Import LLFC	Import MPANs/MSIDs	Export LLFC	Export MPANs/MSIDs	Tariff	Import Super Red unit charge (p/kWh)	Import fixed charge (p/day)	Import capacity charge (p/kVA/day)	Import exceeded capacity charge (p/kVA/day)	Export Super Red unit charge (p/kWh)	Export fixed charge (p/day)	Export capacity charge (p/kVA/day)	Export exceeded capacity charge (p/kVA/day)
739	1700051741086	939	1700051734200	Tariff 044	0.000	22.18	0.65	0.65	0.000	665.47	0.05	0.05
740	1700051754313	940	1700051781520	Tariff 045	0.000	37.96	0.94	0.94	0.000	0.00	0.00	0.00
741	1700051737600	941	1700051733536	Tariff 046	0.000	67.49	0.65	0.65	0.000	703.01	0.05	0.05
742	1700051737610	942	1700051733689	Tariff 047	0.000	2.69	0.65	0.65	0.000	564.80	0.05	0.05
743	1700051746952	943	1700051746961	Tariff 048	0.000	2.25	0.67	0.67	0.000	0.00	0.00	0.00
744	1700051957664	944	1700051957655	Tariff 049	0.000	2376.45	0.65	0.65	0.000	0.00	0.00	0.00
745	1700052002748	945	1700052002710	Tariff 050	0.000	20.52	0.76	0.76	0.000	0.00	0.00	0.00
746	1700052002720	946	1700052002739	Tariff 051	0.000	46.58	0.79	0.79	0.000	0.00	0.00	0.00
748	1700051956466	948	1700051956457	Tariff 052	0.000	2.15	1.75	1.75	0.000	0.00	0.00	0.00
749	1700051622272	949	1700051732151	Tariff 053	0.000	2412.03	3.01	3.01	-1.955	773.89	0.05	0.05
753	1700051965043	953	1700051965052	Tariff 054	0.000	4.06	1.29	1.29	0.000	1193.11	0.05	0.05
754	1700051740923	954	1700051734103	Tariff 055	0.000	0.36	0.65	0.65	0.000	90.31	0.05	0.05
756	1700051770412	956	1700051770403	Tariff 057	0.000	3.99	0.65	0.65	0.000	0.00	0.00	0.00
758	1700051742897	958	1700051732417	Tariff 058	0.000	33.06	0.65	0.65	0.000	0.00	0.00	0.00
589	1700051737629	529	1700051733759	Tariff 059	0.000	0.26	0.65	0.65	0.000	98.11	0.05	0.05
761	1700051751562	961	1700051751553	Tariff 060	0.000	9.31	0.65	0.65	0.000	0.00	0.00	0.00
8694	8694	8694	8694	Tariff 061	0.000	3.60	1.45	1.45	0.000	0.00	0.00	0.00
8694	8694	8694	8694	Tariff 062	0.000	17.81	1.37	1.37	0.000	0.00	0.00	0.00
762	1700051737638	962	1700051733810	Tariff 063	0.000	16.42	0.63	0.63	0.000	1707.76	0.05	0.05
763	1700052250169	963	1700052250178	Tariff 064	0.000	9.86	0.65	0.65	0.000	1037.21	0.05	0.05
767	1700051737683	967	1700051734015	Tariff 065	0.000	17.90	0.65	0.65	0.000	2863.76	0.05	0.05
769	1700051738092	969	1700051734033	Tariff 067	0.000	0.50	2.50	2.50	0.000	156.96	0.05	0.05
8687	8687	8687	8687	Tariff 068	0.000	0.76	0.65	0.65	0.000	160.32	0.05	0.05
772	1700051740950	972	1700051734896	Tariff 069	0.000	6.54	0.65	0.65	0.000	818.06	0.05	0.05
773	1700051742744	973	1700051731690	Tariff 070	0.000	7.31	1.05	1.05	0.000	0.00	0.00	0.00
774	1700051742708	974	1700051731501	Tariff 071	0.000	6.59	0.95	0.95	0.000	0.00	0.00	0.00
633	1700052410683	833	1700052410692	Tariff 072	0.000	107.54	0.61	0.61	0.000	20830.33	0.05	0.05
775	1700051857055	975	1700051857046	Tariff 073	0.000	341.42	0.49	0.49	0.000	0.00	0.00	0.00
777	1700052048593	977	1700052048584	Tariff 074	0.000	41.96	0.65	0.65	0.000	1397.37	0.05	0.05
779	1700051740890	979	1700051734070	Tariff 075	0.000	90.34	0.65	0.65	0.000	2348.87	0.05	0.05
783	1700051740905	983	1700051734089	Tariff 079	0.000	1.45	0.65	0.65	0.000	282.30	0.05	0.05

Import LLFC	Import MPANs/MSIDs	Export LLFC	Export MPANs/MSIDs	Tariff	Import Super Red unit charge (p/kWh)	Import fixed charge (p/day)	Import capacity charge (p/kVA/day)	Import exceeded capacity charge (p/kVA/day)	Export Super Red unit charge (p/kWh)	Export fixed charge (p/day)	Export capacity charge (p/kVA/day)	Export exceeded capacity charge (p/kVA/day)
784	1700051740914	984	1700051734098	Tariff 080	0.000	1.45	0.65	0.65	0.000	282.30	0.05	0.05
		985	1700051744928	Tariff 081	0.000	0.00	0.00	0.00	0.000	2189.95	0.05	0.05
786	1700051742070	986	1700051732356	Tariff 082	0.000	382.00	0.69	0.69	0.000	0.00	0.00	0.00
8689	8689	8689	8689	Tariff 083	0.000	2.37	0.78	0.78	0.000	948.83	0.05	0.05
8689	8689	8689	8689	Tariff 084	0.000	2.70	0.78	0.78	0.000	1080.82	0.05	0.05
789	1700052121427	989	1700052121436	Tariff 085	0.000	2.35	1.30	1.30	0.000	742.93	0.05	0.05
791	1700052276956	991	1700052276983	Tariff 086	0.000	5.08	0.86	0.86	0.000	491.74	0.05	0.05
8740	8740	8740	8740	Tariff 087	0.000	3.98	4.13	4.13	0.000	3563.66	0.05	0.05
607	1700052336027	807	1700052336036	Tariff 088	0.000	19.20	0.79	0.79	0.000	1469.09	0.05	0.05
608	1700052371769	808	1700052371750	Tariff 089	0.000	469.08	0.46	0.46	0.000	0.00	0.00	0.00
729	1700051877993	929	1700051877984	Tariff 090	0.000	56.77	2.14	2.14	0.000	0.00	0.00	0.00
609	1700052335929	809	1700052335938	Tariff 091	0.000	19.30	2.22	2.22	0.000	934.36	0.05	0.05
610	1700052383462	810	1700052383471	Tariff 093	0.000	6.84	0.65	0.65	0.000	721.52	0.05	0.05
611	1700052250016	811	1700052250025	Tariff 094	0.000	8.60	0.68	0.68	0.000	678.66	0.05	0.05
612	1700052333968	812	1700052333977, 1700052755726	Tariff 095	0.000	11.79	0.85	0.85	0.000	2918.51	0.05	0.05
613	1700052409544	813	1700052409553	Tariff 096	0.000	7.48	2.20	2.20	0.000	709.23	0.05	0.05
614	1700052409562	814	1700052409571	Tariff 097	0.000	21.72	0.75	0.75	0.000	2197.60	0.05	0.05
615	1700052279362	815	1700052279353	Tariff 098	0.000	43.39	0.66	0.66	0.000	728.94	0.05	0.05
703	1711837745288			Tariff 099	0.000	3070.63	1.99	1.99	0.000	0.00	0.00	0.00
704	1712407523002			Tariff 100	0.000	13442.20	2.47	2.47	0.000	0.00	0.00	0.00
705	1714107179708			Tariff 101	0.000	13843.77	2.21	2.21	0.000	0.00	0.00	0.00
706	1716846112651, 1700052948191			Tariff 102	0.000	13848.34	3.70	3.70	0.000	0.00	0.00	0.00
707	1717159001300			Tariff 103	0.000	2945.42	1.06	1.06	0.000	0.00	0.00	0.00
708	1717249710102			Tariff 104	0.000	3323.00	1.64	1.64	0.000	0.00	0.00	0.00
710	1717491993500, 1727491993507	855	1700052708503	Tariff 106	0.000	13925.48	2.37	2.37	0.000	132.78	0.05	0.05
711	1712563575006			Tariff 107	0.000	16456.23	0.38	0.38	0.000	0.00	0.00	0.00
685	1711953043404			Tariff 108	1.957	4241.28	2.91	2.91	0.000	0.00	0.00	0.00
686	1712524882004			Tariff 109	0.000	18742.80	3.36	3.36	0.000	0.00	0.00	0.00

Import LLFC	Import MPANs/MSIDs	Export LLFC	Export MPANs/MSIDs	Tariff	Import Super Red unit charge (p/kWh)	Import fixed charge (p/day)	Import capacity charge (p/kVA/day)	Import exceeded capacity charge (p/kVA/day)	Export Super Red unit charge (p/kWh)	Export fixed charge (p/day)	Export capacity charge (p/kVA/day)	Export exceeded capacity charge (p/kVA/day)
687	1711843426252			Tariff 110	0.000	2922.49	0.79	0.79	0.000	0.00	0.00	0.00
688	1711929555006			Tariff 111	0.000	7123.21	4.05	4.05	0.000	0.00	0.00	0.00
638	1700051744440	838	1700051744459	Tariff 112	0.000	123.58	0.39	0.39	0.000	187.24	0.05	0.05
689	1735033416884	900	-	Tariff 122	0.000	13041.25	2.53	2.53	0.000	144.28	0.05	0.05
689	1745033416880	900	-	Tariff 123	0.000	189.04	2.56	2.56	0.000	141.78	0.05	0.05
689	1725033416888	900	-	Tariff 124	0.000	116.76	2.08	2.08	0.000	214.06	0.05	0.05
689	1715033416881	900	-	Tariff 125	0.000	111.01	2.09	2.09	0.000	219.81	0.05	0.05
690	1715033416924			Tariff 126	0.000	13185.53	1.88	1.88	0.000	0.00	0.00	0.00
690	1725033416920			Tariff 127	0.000	330.82	2.70	2.70	0.000	0.00	0.00	0.00
616	1700052338353	816	1700052338362	Tariff 128	0.000	16.96	0.74	0.74	0.000	3550.68	0.05	0.05
617	1700052478830	817	1700052478840	Tariff 129	0.000	23.06	0.67	0.67	0.000	930.16	0.05	0.05
618	1700052478868	818	1700052478877	Tariff 130	0.000	59.83	0.66	0.66	0.000	1447.81	0.05	0.05
619	1700052478812	819	1700052478821	Tariff 131	0.000	26.58	0.66	0.66	0.000	1072.15	0.05	0.05
620	1700052464740	820	1700052464759	Tariff 132	0.000	335.32	2.30	2.30	0.000	856.94	0.05	0.05
621	1700052372178	821	1700052372187	Tariff 133	0.000	52.25	0.65	0.65	0.000	2205.15	0.05	0.05
622	1700052288701	822	1700052288696	Tariff 134	0.000	70.68	0.47	0.47	0.000	0.00	0.00	0.00
623	1700052434197	823	1700052434211	Tariff 135	0.000	5.10	0.86	0.86	0.000	805.95	0.05	0.05
625	1700052427320	825	1700052427330	Tariff 136	0.000	57.79	0.65	0.65	0.000	1155.86	0.05	0.05
626	1700052468489	826	1700052468498	Tariff 137	0.000	7.27	0.90	0.90	0.000	0.00	0.00	0.00
766	1700051744430	966	1700051744421	Tariff 138	0.000	145.36	0.38	0.38	0.000	2689.13	0.05	0.05
793	1700052446280	8710	8710	Tariff 140	0.000	12.29	2.83	2.83	0.000	12500.15	0.05	0.05
630	1700052708187	830	1700052708196	Tariff 141	0.000	220.83	1.08	1.08	0.000	761.85	0.05	0.05
634	1700052479268	834	1700052479277	Tariff 143	0.000	3.09	0.65	0.65	0.000	711.20	0.05	0.05
635	1700052632341	835	1700052632350	Tariff 144	0.000	33.49	0.68	0.68	0.000	4107.90	0.05	0.05
790	1700052250248	990	1700052250284	Tariff 146	0.000	16.80	0.66	0.66	0.000	1220.03	0.05	0.05
644	1700051778192	844	1700051778183	Tariff 147	0.000	35.74	0.45	0.45	0.000	0.00	0.00	0.00
646	1700052537803	846	1700052537812	Tariff 149	0.000	2.04	0.79	0.79	0.000	494.77	0.05	0.05
648	1700052909174	848	1700052909183	Tariff 150	0.000	4.60	1.18	1.18	0.000	506.50	0.05	0.05
8715	8715	8715	8715	Tariff 151	0.000	14.66	3.86	3.86	0.000	7725.84	0.05	0.05
652	1700052674875	852	1700052674884	Tariff 153	0.000	61.28	0.65	0.65	0.000	6127.91	0.05	0.05
653	1700052577772	853	1700052577781	Tariff 154	0.000	12.43	0.70	0.70	0.000	1715.24	0.05	0.05

Import LLFC	Import MPANs/MSIDs	Export LLFC	Export MPANs/MSIDs	Tariff	Import Super Red unit charge (p/kWh)	Import fixed charge (p/day)	Import capacity charge (p/kVA/day)	Import exceeded capacity charge (p/kVA/day)	Export Super Red unit charge (p/kWh)	Export fixed charge (p/day)	Export capacity charge (p/kVA/day)	Export exceeded capacity charge (p/kVA/day)
654	1700052635991	854	1700052636008	Tariff 155	0.000	7.42	0.79	0.79	0.000	489.40	0.05	0.05
795	1700052588250	859	1700052588296	Tariff 157	0.000	107.16	0.65	0.65	0.000	389.66	0.05	0.05
796	1700052844312	860	1700052844321	Tariff 158	0.000	8.43	0.80	0.80	0.000	1938.05	0.05	0.05
797	1700052585286	8717	8717	Tariff 159	0.000	51.29	1.16	1.16	0.000	6411.51	0.05	0.05
658	1700052525366	863	1700052525375	Tariff 161	0.000	64.81	1.60	1.60	0.000	16202.98	0.05	0.05
655	1700052524098	864	1700052524103	Tariff 162	0.000	3.69	2.95	2.95	0.000	733.51	0.05	0.05
659	1700052500724	865	1700052500733	Tariff 163	0.000	43.97	2.01	2.01	0.000	10860.24	0.05	0.05
661	1700052601770	867	1700052601812	Tariff 165	0.000	18.03	0.66	0.66	0.000	1932.07	0.05	0.05
624	1700052765487	824	1700052765496	Tariff 166	0.000	18.49	0.65	0.65	0.000	850.31	0.05	0.05
664	1700052793182	870	1700052793207	Tariff 170	0.000	126.30	0.65	0.65	0.000	2185.91	0.05	0.05
665	1700052556300	871	1700052556319	Tariff 171	0.000	16.80	0.67	0.67	0.000	772.86	0.05	0.05
778	1700051768167	978	1700051768158	Tariff 172	0.000	32.00	2.32	2.32	0.000	1223.05	0.05	0.05
667	1700052479212	873	1700052479221	Tariff 174	0.000	58.27	0.69	0.69	0.000	2777.33	0.05	0.05
691	1700051747715			Tariff 177	0.000	666.98	1.34	1.34	0.000	0.00	0.00	0.00
691	1700051747733			Tariff 178	0.000	666.98	1.91	1.91	0.000	0.00	0.00	0.00
		528	1700051731194	Tariff 179	0.000	0.00	0.00	0.00	0.000	310.82	0.05	0.05
		528	1700051731185	Tariff 180	0.000	0.00	0.00	0.00	0.000	310.82	0.05	0.05
		528	1700051731176	Tariff 181	0.000	0.00	0.00	0.00	0.000	310.82	0.05	0.05
		528	1700051731120	Tariff 182	0.000	0.00	0.00	0.00	0.000	310.82	0.05	0.05
		528	1700051731088	Tariff 183	0.000	0.00	0.00	0.00	0.000	310.82	0.05	0.05
		528	1700051731200	Tariff 184	0.000	0.00	0.00	0.00	0.000	310.82	0.05	0.05
		528	1700051730846	Tariff 185	0.000	0.00	0.00	0.00	0.000	310.82	0.05	0.05
		528	1700051730873	Tariff 186	0.000	0.00	0.00	0.00	0.000	310.82	0.05	0.05
		528	1700051730882	Tariff 187	0.000	0.00	0.00	0.00	0.000	310.82	0.05	0.05
		843	1700051730891	Tariff 188	0.000	0.00	0.00	0.00	0.000	666.98	0.05	0.05
		843	1700051730943	Tariff 189	0.000	0.00	0.00	0.00	0.000	666.98	0.05	0.05
		843	1700051730916	Tariff 190	0.000	0.00	0.00	0.00	0.000	666.98	0.05	0.05
668	1700052336009	874	1700052336018	Tariff 191	0.000	28.81	0.71	0.71	0.000	1457.98	0.05	0.05
669	1700052611323	875	1700052611332	Tariff 192	0.000	61.00	1.40	1.40	0.000	7319.88	0.05	0.05
780	1700052910658	980	1700052910667	Tariff 194	0.000	229.08	0.80	0.80	0.000	11442.46	0.05	0.05
673	1700052767128	879	1700052767137	Tariff 196	0.000	10.24	0.65	0.65	0.000	818.56	0.05	0.05

Import LLFC	Import MPANs/MSIDs	Export LLFC	Export MPANs/MSIDs	Tariff	Import Super Red unit charge (p/kWh)	Import fixed charge (p/day)	Import capacity charge (p/kVA/day)	Import exceeded capacity charge (p/kVA/day)	Export Super Red unit charge (p/kWh)	Export fixed charge (p/day)	Export capacity charge (p/kVA/day)	Export exceeded capacity charge (p/kVA/day)
647	1700052610348	847	1700052610357	Tariff 197	0.000	5.72	0.81	0.81	0.000	569.49	0.05	0.05
583	1712392333485			Tariff 200	0.000	2988.36	7.66	7.66	0.000	0.00	0.00	0.00
675	1700052707945	881	1700052707963	Tariff 202	0.000	481.50	1.24	1.24	0.000	1476.59	0.05	0.05
676	1700052445729	882	1700052445738	Tariff 203	0.000	4.68	0.71	0.71	0.000	748.69	0.05	0.05
677	1700052638539	883	1700052638548	Tariff 204	0.000	34.25	1.18	1.18	0.000	6781.16	0.05	0.05
679	1700052643929	885	1700052643938	Tariff 206	0.000	5.60	0.70	0.70	0.000	1288.53	0.05	0.05
680	1700052636150	886	1700052636160	Tariff 207	0.000	6.49	0.65	0.65	0.000	518.90	0.05	0.05
681	1700052601413	887	1700052601469	Tariff 208	0.000	3.62	0.65	0.65	0.000	0.00	0.00	0.00
682	1700052604567	888	1700052604576	Tariff 209	0.000	10.39	0.76	0.76	0.000	1308.66	0.05	0.05
692	1700052619439	891	1700052619448	Tariff 212	0.000	196.50	0.67	0.67	0.000	6288.06	0.05	0.05
694	1700052643593	893	1700052643609	Tariff 214	0.000	286.56	2.04	2.04	0.000	3868.55	0.05	0.05
8720	8720	8720	8720	Tariff 215	0.000	60.40	0.42	0.42	0.000	6225.92	0.05	0.05
696	1700052667450	895	1700052667460	Tariff 216	0.000	16.89	0.65	0.65	0.000	776.76	0.05	0.05
697	1700052667423	896	1700052667432	Tariff 217	0.000	16.20	0.70	0.70	0.000	777.45	0.05	0.05
656	1700052613757	856	1700052613766	Tariff 221	0.000	16.60	0.97	0.97	0.000	4481.28	0.05	0.05
577	1700052218990, 1700052219007			Tariff 228	0.000	31763.09	0.40	0.40	0.000	0.00	0.00	0.00
8719	8719	8719	8719	Tariff 230	0.000	213.36	0.57	0.57	0.000	12404.57	0.05	0.05
581	1700052632379	908	1700052632388	Tariff 232	0.000	31.99	0.84	0.84	0.000	2111.25	0.05	0.05
631	1700052750685	831	1700052750694	Tariff 234	0.000	51.41	0.71	0.71	0.000	616.95	0.05	0.05
636	1700052757705	836	1700052757714	Tariff 235	0.000	3.33	2.36	2.36	0.000	665.03	0.05	0.05
771	1700052979793	971	1700052979809	Tariff 237	0.000	55.05	0.67	0.67	0.000	2642.17	0.05	0.05
8707	8707	8707	8707	Tariff 238	0.000	2.72	0.51	0.51	0.000	0.00	0.00	0.00
750	1700052546774			Tariff 239	0.000	4262.62	0.66	0.66	0.000	0.00	0.00	0.00
628	1700052708201	828	1700052708210	Tariff 240	0.000	79.04	0.58	0.58	0.000	0.00	0.00	0.00
781	1700052765469	981	1700052765478	Tariff 241	0.000	529.90	2.09	2.09	0.000	7895.53	0.05	0.05
639	1700052751331	839	1700052751340	Tariff 242	0.000	139.05	0.66	0.66	0.000	2398.59	0.05	0.05
8722	8722	8722	8722	Tariff 246	0.000	769.81	0.46	0.46	0.000	28482.90	0.05	0.05
570	1700052616916	970	1700052616925	Tariff 249	0.000	302.22	2.64	2.64	0.000	30222.36	0.05	0.05
576	1700052791343	876	1700052791361	Tariff 251	0.000	77.66	0.65	0.65	0.000	1320.21	0.05	0.05
580	1700052906944	880	1700052906953	Tariff 252	0.000	7.21	0.65	0.65	0.000	1081.90	0.05	0.05

Import LLFC	Import MPANs/MSIDs	Export LLFC	Export MPANs/MSIDs	Tariff	Import Super Red unit charge (p/kWh)	Import fixed charge (p/day)	Import capacity charge (p/kVA/day)	Import exceeded capacity charge (p/kVA/day)	Export Super Red unit charge (p/kWh)	Export fixed charge (p/day)	Export capacity charge (p/kVA/day)	Export exceeded capacity charge (p/kVA/day)
640	1700052750408	840	1700052750417	Tariff 253	0.000	16.90	0.69	0.69	0.000	777.19	0.05	0.05
629	1700052730856	829	1700052730865	Tariff 254	0.000	4.24	0.65	0.65	0.000	714.45	0.05	0.05
8741	8741	8741	8741	Tariff 255	0.000	139.60	0.79	0.79	0.000	31409.58	0.05	0.05
641	1700052708586	841	1700052708595	Tariff 256	0.000	26.00	0.65	0.65	0.000	1169.81	0.05	0.05
782	1700052966039	982	1700052966048	Tariff 257	0.000	52.41	0.42	0.42	0.000	4926.90	0.05	0.05
590	1700053150075	531	1700053150084	Tariff 258	0.000	26.78	0.78	0.78	0.000	6158.28	0.05	0.05
645	1700052867514	845	1700052867523	Tariff 259	0.000	2.81	0.65	0.65	0.000	842.58	0.05	0.05
649	1700052944504	849	1700052944513	Tariff 260	0.000	2.35	2.96	2.96	0.000	774.61	0.05	0.05
792	1700053043267	992	1700053043276	Tariff 262	0.000	6.13	0.39	0.39	0.000	490.68	0.05	0.05
734	1700052967219	934	1700052967246	Tariff 263	0.000	19.43	0.74	0.74	0.000	1589.76	0.05	0.05
693	1700052810094	933	1700052810100	Tariff 265	0.000	174.39	0.87	0.87	0.000	1150.96	0.05	0.05
799	1700053292294	960	1700053292285	Tariff 266	0.000	3.81	0.72	0.72	0.000	761.26	0.05	0.05
695	1700052348254	995	1700052348263	Tariff 269	0.000	647.84	0.67	0.67	0.000	14576.49	0.05	0.05
764	1700053001080	964	1700053001090	Tariff 273	0.000	244.10	0.66	0.66	0.000	16842.99	0.05	0.05
627	1700052434620	827	1700052434639	Tariff 274	0.000	71.01	0.85	0.85	0.000	2644.34	0.05	0.05
698	1700052878000	898	1700052878010	Tariff 277	0.000	22.53	2.51	2.51	0.000	781.99	0.05	0.05
666	1700053065048	996	1700053065057	Tariff 282	0.000	4.49	1.50	1.50	0.000	897.90	0.05	0.05
642	1700052768380	842	1700052768390	Tariff 286	0.000	4.50	3.11	3.11	0.000	697.69	0.05	0.05
699	1700052826698	899	1700052826917	Tariff 287	0.000	4.95	0.68	0.68	0.000	2275.01	0.05	0.05
8727	8727	8727	8727	Tariff 288	0.000	209.14	1.09	1.09	0.000	35852.10	0.05	0.05
702	1700052857534	902	1700052857543	Tariff 289	0.000	5.55	0.94	0.94	0.000	647.09	0.05	0.05
712	1700052859903	912	1700052859912	Tariff 290	0.000	3.07	0.73	0.73	0.000	1228.68	0.05	0.05
794	1700052887690	994	1700052887706	Tariff 291	0.000	10.16	1.36	1.36	0.000	677.23	0.05	0.05
716	1700052889721	916	1700052889730	Tariff 292	0.000	0.99	0.88	0.88	0.000	495.82	0.05	0.05
719	1700052866733	919	1700052866742	Tariff 295	0.000	1.41	2.13	2.13	0.000	334.48	0.05	0.05
765	1700052930014	965	1700052930023	Tariff 296	0.000	10.38	0.73	0.73	0.000	1383.33	0.05	0.05
585	1700053106800	8755	8755	Tariff 299	0.000	4.22	0.84	0.84	0.000	492.59	0.05	0.05
799	1700052918959	960	1700052918968	Tariff 300	0.000	102.81	1.51	1.51	0.000	1151.44	0.05	0.05
776	1700052976686	976	1700052976700	Tariff 302	0.000	91.97	0.66	0.66	0.000	3112.99	0.05	0.05
657	1700052983390	857	1700052983406	Tariff 303	0.000	7.70	0.65	0.65	0.000	770.00	0.05	0.05
594	1700053110676	533	1700053110685	Tariff 311	0.000	271.83	0.40	0.40	0.000	2785.17	0.05	0.05

Import LLFC	Import MPANs/MSIDs	Export LLFC	Export MPANs/MSIDs	Tariff	Import Super Red unit charge (p/kWh)	Import fixed charge (p/day)	Import capacity charge (p/kVA/day)	Import exceeded capacity charge (p/kVA/day)	Export Super Red unit charge (p/kWh)	Export fixed charge (p/day)	Export capacity charge (p/kVA/day)	Export exceeded capacity charge (p/kVA/day)
747	1700052947453	947	1700052947620	Tariff 312	0.000	12.80	0.65	0.65	0.000	1047.25	0.05	0.05
757	1700052947791	957	1700052947807	Tariff 317	0.000	21.71	0.66	0.66	0.000	759.80	0.05	0.05
672	1700052944531	872	1700052944540	Tariff 320	0.000	2.58	0.68	0.68	0.000	858.62	0.05	0.05
768	1700052959218	968	1700052959227	Tariff 322	0.000	13.58	1.11	1.11	0.000	678.74	0.05	0.05
674	1700053106829	894	1700053106838	Tariff 327	0.000	3.22	0.73	0.73	0.000	493.60	0.05	0.05
728	1700052988877	878	1700052988886	Tariff 331	0.000	13.07	0.65	0.65	0.000	483.74	0.05	0.05
751	1700052988840	911	1700052988859	Tariff 334	0.000	15.55	0.65	0.65	0.000	933.27	0.05	0.05
720	1700052866760	920	1700052866770	Tariff 340	0.000	5.20	2.82	2.82	0.000	861.42	0.05	0.05
8752	8752	8756	8752	Tariff 342	0.000	12.28	0.48	0.48	0.000	1218.19	0.05	0.05
788	1700053037510	988	1700053037529	Tariff 348	0.000	4.35	2.20	2.20	0.000	724.46	0.05	0.05
799	-	960	-	Tariff 350	0.000	88.43	2.50	2.50	0.000	3802.39	0.05	0.05
721	1700052954655	921	1700052954664	Tariff 355	0.000	1.23	0.81	0.81	0.000	614.57	0.05	0.05
798	1700052963083	998	1700052963092	Tariff 356	0.000	10.69	3.97	3.97	0.000	486.12	0.05	0.05
670	1700053127721	8738	8738	Tariff 357	0.000	11.07	1.18	1.18	0.000	2371.54	0.05	0.05
759	1700052976792	959	1700052976808	Tariff 358	0.000	3.35	0.65	0.65	0.000	669.40	0.05	0.05
671	1700052982909	901	1700052982927	Tariff 359	0.000	1.41	2.13	2.13	0.000	334.48	0.05	0.05
785	1700053058797	905	1700053058802	Tariff 362	0.000	273.92	0.72	0.72	0.000	12326.35	0.05	0.05
643	1700053092158			Tariff 363	0.000	3025.53	4.41	4.41	0.000	0.00	0.00	0.00
760	1700053127730	8737	8737	Tariff 364	0.000	27.14	0.41	0.41	0.000	1872.72	0.05	0.05
572	1700052996655	862	1700052996664	Tariff 365	0.000	10.26	2.24	2.24	0.000	718.54	0.05	0.05
8743	8743	8743	8743	Tariff 367	0.000	8.14	0.94	0.94	0.000	488.67	0.05	0.05
591	1700053137232	8757	8757	Tariff 369	0.000	186.88	0.46	0.46	0.000	16018.49	0.05	0.05
663	1700053029244	897	1700053029253	Tariff 372	0.000	96.36	0.69	0.69	0.000	8864.85	0.05	0.05
799	1700053276195	960	1700053276200	Tariff 375	0.000	7.17	0.72	0.72	0.000	716.78	0.05	0.05
683	1700053048070	907	1700053048089	Tariff 377	0.000	6.13	1.17	1.17	0.000	715.42	0.05	0.05
733	1700053036241	997	1700053036250	Tariff 379	0.000	0.43	2.75	2.75	0.000	496.39	0.05	0.05
752	1700053043285	892	1700053043294	Tariff 380	0.000	13.52	0.66	0.66	0.000	1081.24	0.05	0.05
573	1700053043300	993	1700053043319	Tariff 381	0.000	6.13	0.66	0.66	0.000	490.68	0.05	0.05
770	1700053062419			Tariff 382	0.000	21183.37	4.99	4.99	0.000	0.00	0.00	0.00
799	-	960	-	Tariff 383	0.000	158.99	0.72	0.72	0.000	1510.36	0.05	0.05
592	1700053164022			Tariff 384	0.000	21427.08	1.52	1.52	0.000	0.00	0.00	0.00

Import LLFC	Import MPANs/MSIDs	Export LLFC	Export MPANs/MSIDs	Tariff	Import Super Red unit charge (p/kWh)	Import fixed charge (p/day)	Import capacity charge (p/kVA/day)	Import exceeded capacity charge (p/kVA/day)	Export Super Red unit charge (p/kWh)	Export fixed charge (p/day)	Export capacity charge (p/kVA/day)	Export exceeded capacity charge (p/kVA/day)
700	1700053104965	858	1700053104974	Tariff 387	0.000	45.17	0.65	0.65	0.000	451.65	0.05	0.05
593	1700053187039	532	1700053187048	Tariff 389	0.000	794.57	0.78	0.78	0.000	29872.71	0.05	0.05
799	1700053289868	960	1700053289877	Tariff 390	0.000	1.52	0.72	0.72	0.000	691.01	0.05	0.05
568	1700053141762, 1700053152392	538	1700053141771, 1700053152408	Tariff 392	0.000	23298.06	1.57	1.57	0.000	2452.69	0.05	0.05
799	1700053339473	8764	8764	Tariff 393	0.000	53.22	0.53	0.53	0.000	8099.25	0.05	0.05
799	-	960	-	Tariff 396	0.000	411.68	0.53	0.53	0.000	18937.49	0.05	0.05
584	1700053240055	534	1700053240064	Tariff 416	0.000	5.82	1.30	1.30	0.000	820.63	0.05	0.05
799	1700053287930	960	1700053282134	Tariff 426	0.000	12.43	0.72	0.72	0.000	2486.35	0.05	0.05
799	-	960	-	Tariff 433	0.000	570.16	0.53	0.53	0.000	570.16	0.05	0.05
799	-	960	-	Tariff 434	0.000	9.44	0.72	0.72	0.000	924.33	0.05	0.05
799	1700053343424	960	1700053343433	Tariff 436	0.000	5.52	0.45	0.45	0.000	518.63	0.05	0.05
799	-	960	-	Tariff 439	0.000	78.44	0.80	0.80	0.000	418.37	0.05	0.05
8760	8760	8760	8760	Tariff 440	0.000	127.32	0.53	0.53	0.000	18188.13	0.05	0.05
799	1700053298890	960	1700053298905	Tariff 443	0.000	16.30	0.72	0.72	0.000	2608.09	0.05	0.05
799	1700053280182	960	1700053280191	Tariff 444	0.000	2443.67	0.80	0.80	0.000	362.51	0.05	0.05
799	-	960	-	Tariff 445	0.000	840.61	0.53	0.53	0.000	840.61	0.05	0.05
799	-	960	-	Tariff 446	0.000	815.84	0.55	0.55	0.000	815.84	0.05	0.05
799	-	960	-	Tariff 447	0.000	519.89	0.53	0.53	0.000	519.89	0.05	0.05
799	-	960	-	Tariff 448	0.000	4.20	0.72	0.72	0.000	835.32	0.05	0.05
799	-	960	-	Tariff 449	0.000	22.80	2.56	2.56	0.000	9118.02	0.05	0.05
799	-	960	-	Tariff 450	0.000	18.63	0.80	0.80	0.000	1780.07	0.05	0.05

Annex 3 - Schedule of Charges for use of the Distribution System by Preserved/Additional LLF Classes

Scottish Hydro Electric Power Distribution plc - Effective from 1 April 2022 - Final LV and HV tariffs

Supercustomer preserved charges/additional LLFCs									
	Closed LLFCs	PCs	Red/black unit charge p/kWh	Amber/yellow unit charge p/kWh	Green unit charge p/kWh	Fixed charge p/MPAN/day			
Domestic Aggregated (Related MPAN)	17, 20, 104, 124, 304, 324	2	8.758	1.821	0.634				
Non-Domestic Aggregated No Residual	S00, S15, S20	0, 3, 4, 5-8	10.050	2.089	0.727	10.37			
Non-Domestic Aggregated Band 1	S01, S16, S21	0, 3, 4, 5-8	10.050	2.089	0.727	13.38			
Non-Domestic Aggregated Band 2	S02, S17, S22	0, 3, 4, 5-8	10.050	2.089	0.727	28.17			
Non-Domestic Aggregated Band 3	S03, S18, S23	0, 3, 4, 5-8	10.050	2.089	0.727	54.30			
Non-Domestic Aggregated Band 4	S04, S19, S24	0, 3, 4, 5-8	10.050	2.089	0.727	154.10			
Non-Domestic Aggregated (related MPAN)	155, 175, 355, 375	4	10.050	2.089	0.727				

Site Specific preserved charges/additional LLFCs									
	Closed LLFCs	PCs	Red/black unit charge p/kWh	Amber/yellow unit charge p/kWh	Green unit charge p/kWh	Fixed charge p/MPAN/day	Capacity charge p/kVA/day	Exceeded capacity charge p/kVA/day	Reactive power charge p/kVArh
		0							

Annex 4 - Charges applied to LDNOs with HV/LV end users

Scottish Hydro Electric Power Distribution plc - Effective from 1st April 2022 - Final LDNO Tariffs

Time Bands for Half Hourly Metered Properties			
Time periods	Red Time Band	Amber Time Band	Green Time Band
Monday to Friday (Including Bank Holidays) All Year	16:00 - 19:00		
Monday to Friday (Including Bank Holidays) All Year		07:00 - 16:00 19:00 - 21:00	
Monday to Friday (Including Bank Holidays) All Year			00:00 - 07:00 21:00 - 24:00
Saturday and Sunday All Year		12:00 - 20:00	00:00 - 12:00 20:00 - 24:00
Notes	All the above times are in UK Clock time		

Time Bands for Half Hourly Unmetered Properties			
	Black Time Band	Yellow Time Band	Green Time Band
Monday to Friday (Including Bank Holidays) March to October		07:00 - 21:00	
Monday to Friday (Including Bank Holidays) November to February	16:00 - 19:00	07:00 - 16:00 19:00 - 21:00	
Monday to Friday (Including Bank Holidays) April to March			00:00 - 07:00 21:00 - 24:00
Saturday and Sunday All Year		12:00 - 20:00	00:00 - 12:00 20:00 - 24:00
Notes	All the above times are in UK Clock time		

Tariff name	Unique billing identifier	PCs	Red/black unit charge p/kWh	Amber/yellow unit charge p/kWh	Green unit charge p/kWh	Fixed charge p/MPAN/day	Capacity charge p/kVA/day	Exceeded capacity charge p/kVA/day	Reactive power charge p/kVArh
LDNO LV: Domestic Aggregated with Residual		0, 1, 2	6.186	1.286	0.448	22.34			
LDNO LV: Domestic Aggregated (Related MPAN)		2	6.186	1.286	0.448				
LDNO LV: Non-Domestic Aggregated No Residual		0, 3, 4, 5-8	7.098	1.476	0.514	7.34			

Tariff name	Unique billing identifier	PCs	Red/black unit charge p/kWh	Amber/yellow unit charge p/kWh	Green unit charge p/kWh	Fixed charge p/MPAN/day	Capacity charge p/kVA/day	Exceeded capacity charge p/kVA/day	Reactive power charge p/kVArh
LDNO LV: Non-Domestic Aggregated Band 1		0, 3, 4, 5-8	7.098	1.476	0.514	9.46			
LDNO LV: Non-Domestic Aggregated Band 2		0, 3, 4, 5-8	7.098	1.476	0.514	19.91			
LDNO LV: Non-Domestic Aggregated Band 3		0, 3, 4, 5-8	7.098	1.476	0.514	38.37			
LDNO LV: Non-Domestic Aggregated Band 4		0, 3, 4, 5-8	7.098	1.476	0.514	108.86			
LDNO LV: Non-Domestic Aggregated (related MPAN)		4	7.098	1.476	0.514				
LDNO LV: LV Site Specific No Residual		0	5.116	1.036	0.363	19.21	3.85	6.73	0.205
LDNO LV: LV Site Specific Band 1		0	5.116	1.036	0.363	178.94	3.85	6.73	0.205
LDNO LV: LV Site Specific Band 2		0	5.116	1.036	0.363	319.99	3.85	6.73	0.205
LDNO LV: LV Site Specific Band 3		0	5.116	1.036	0.363	520.50	3.85	6.73	0.205
LDNO LV: LV Site Specific Band 4		0	5.116	1.036	0.363	1191.29	3.85	6.73	0.205
LDNO LV: Unmetered Supplies		0, 1 or 8	12.299	3.454	2.771				
LDNO LV: LV Generation Aggregated		0 or 8	-6.770	-1.407	-0.490	0.00			
LDNO LV: LV Generation Site Specific		0	-6.770	-1.407	-0.490	0.00			0.284

Tariff name	Unique billing identifier	PCs	Red/black unit charge p/kWh	Amber/yellow unit charge p/kWh	Green unit charge p/kWh	Fixed charge p/MPAN/day	Capacity charge p/kVA/day	Exceeded capacity charge p/kVA/day	Reactive power charge p/kVArh
LDNO HV: Domestic Aggregated with Residual		0, 1, 2	4.094	0.851	0.296	18.14			
LDNO HV: Domestic Aggregated (Related MPAN)		2	4.094	0.851	0.296				
LDNO HV: Non-Domestic Aggregated No Residual		0, 3, 4, 5-8	4.698	0.977	0.340	4.87			
LDNO HV: Non-Domestic Aggregated Band 1		0, 3, 4, 5-8	4.698	0.977	0.340	6.28			
LDNO HV: Non-Domestic Aggregated Band 2		0, 3, 4, 5-8	4.698	0.977	0.340	13.20			
LDNO HV: Non-Domestic Aggregated Band 3		0, 3, 4, 5-8	4.698	0.977	0.340	25.41			
LDNO HV: Non-Domestic Aggregated Band 4		0, 3, 4, 5-8	4.698	0.977	0.340	72.06			
LDNO HV: Non-Domestic Aggregated (related MPAN)		4	4.698	0.977	0.340				
LDNO HV: LV Site Specific No Residual		0	3.386	0.685	0.240	12.73	2.55	4.45	0.136
LDNO HV: LV Site Specific Band 1		0	3.386	0.685	0.240	118.44	2.55	4.45	0.136
LDNO HV: LV Site Specific Band 2		0	3.386	0.685	0.240	211.79	2.55	4.45	0.136
LDNO HV: LV Site Specific Band 3		0	3.386	0.685	0.240	344.49	2.55	4.45	0.136
LDNO HV: LV Site Specific Band 4		0	3.386	0.685	0.240	788.43	2.55	4.45	0.136

Tariff name	Unique billing identifier	PCs	Red/black unit charge p/kWh	Amber/yellow unit charge p/kWh	Green unit charge p/kWh	Fixed charge p/MPAN/day	Capacity charge p/kVA/day	Exceeded capacity charge p/kVA/day	Reactive power charge p/kVArh
LDNO HV: LV Sub Site Specific No Residual		0	2.527	0.457	0.166	43.09	5.82	7.88	0.093
LDNO HV: LV Sub Site Specific Band 1		0	2.527	0.457	0.166	195.70	5.82	7.88	0.093
LDNO HV: LV Sub Site Specific Band 2		0	2.527	0.457	0.166	330.46	5.82	7.88	0.093
LDNO HV: LV Sub Site Specific Band 3		0	2.527	0.457	0.166	522.04	5.82	7.88	0.093
LDNO HV: LV Sub Site Specific Band 4		0	2.527	0.457	0.166	1162.93	5.82	7.88	0.093
LDNO HV: HV Site Specific No Residual		0	1.933	0.335	0.130	237.60	8.60	10.01	0.069
LDNO HV: HV Site Specific Band 1		0	1.933	0.335	0.130	547.02	8.60	10.01	0.069
LDNO HV: HV Site Specific Band 2		0	1.933	0.335	0.130	2645.49	8.60	10.01	0.069
LDNO HV: HV Site Specific Band 3		0	1.933	0.335	0.130	5416.78	8.60	10.01	0.069
LDNO HV: HV Site Specific Band 4		0	1.933	0.335	0.130	11611.58	8.60	10.01	0.069
LDNO HV: Unmetered Supplies		0, 1 or 8	8.140	2.286	1.834				
LDNO HV: LV Generation Aggregated		0 or 8	-6.770	-1.407	-0.490	0.00			
LDNO HV: LV Sub Generation Aggregated		0 or 8	-6.063	-1.246	-0.435	0.00			

Tariff name	Unique billing identifier	PCs	Red/black unit charge p/kWh	Amber/yellow unit charge p/kWh	Green unit charge p/kWh	Fixed charge p/MPAN/day	Capacity charge p/kVA/day	Exceeded capacity charge p/kVA/day	Reactive power charge p/kVArh
LDNO HV: LV Generation Site Specific		0	-6.770	-1.407	-0.490	0.00			0.284
LDNO HV: LV Sub Generation Site Specific		0	-6.063	-1.246	-0.435	0.00			0.238
LDNO HV: HV Generation Site Specific		0	-3.399	-0.615	-0.224	0.00			0.216

Tariff name	Unique billing identifier	PCs	Red/black unit charge p/kWh	Amber/yellow unit charge p/kWh	Green unit charge p/kWh	Fixed charge p/MPAN/day	Capacity charge p/kVA/day	Exceeded capacity charge p/kVA/day	Reactive power charge p/kVArh
LDNO HVplus: Domestic Aggregated with Residual		0, 1, 2	2.648	0.550	0.192	15.24			
LDNO HVplus: Domestic Aggregated (Related MPAN)		2	2.648	0.550	0.192				
LDNO HVplus: Non-Domestic Aggregated No Residual		0, 3, 4, 5-8	3.039	0.632	0.220	3.17			
LDNO HVplus: Non-Domestic Aggregated Band 1		0, 3, 4, 5-8	3.039	0.632	0.220	4.08			
LDNO HVplus: Non-Domestic Aggregated Band 2		0, 3, 4, 5-8	3.039	0.632	0.220	8.55			
LDNO HVplus: Non-Domestic Aggregated Band 3		0, 3, 4, 5-8	3.039	0.632	0.220	16.45			
LDNO HVplus: Non-Domestic Aggregated Band 4		0, 3, 4, 5-8	3.039	0.632	0.220	46.63			
LDNO HVplus: Non-Domestic Aggregated (related MPAN)		4	3.039	0.632	0.220				

Tariff name	Unique billing identifier	PCs	Red/black unit charge p/kWh	Amber/yellow unit charge p/kWh	Green unit charge p/kWh	Fixed charge p/MPAN/day	Capacity charge p/kVA/day	Exceeded capacity charge p/kVA/day	Reactive power charge p/kVArh
LDNO HVplus: LV Site Specific No Residual		0	2.190	0.443	0.156	8.25	1.65	2.88	0.088
LDNO HVplus: LV Site Specific Band 1		0	2.190	0.443	0.156	76.63	1.65	2.88	0.088
LDNO HVplus: LV Site Specific Band 2		0	2.190	0.443	0.156	137.01	1.65	2.88	0.088
LDNO HVplus: LV Site Specific Band 3		0	2.190	0.443	0.156	222.85	1.65	2.88	0.088
LDNO HVplus: LV Site Specific Band 4		0	2.190	0.443	0.156	510.01	1.65	2.88	0.088
LDNO HVplus: LV Sub Site Specific No Residual		0	1.588	0.287	0.104	27.09	3.66	4.95	0.058
LDNO HVplus: LV Sub Site Specific Band 1		0	1.588	0.287	0.104	122.97	3.66	4.95	0.058
LDNO HVplus: LV Sub Site Specific Band 2		0	1.588	0.287	0.104	207.64	3.66	4.95	0.058
LDNO HVplus: LV Sub Site Specific Band 3		0	1.588	0.287	0.104	328.00	3.66	4.95	0.058
LDNO HVplus: LV Sub Site Specific Band 4		0	1.588	0.287	0.104	730.66	3.66	4.95	0.058
LDNO HVplus: HV Site Specific No Residual		0	1.204	0.209	0.081	148.09	5.36	6.24	0.043
LDNO HVplus: HV Site Specific Band 1		0	1.204	0.209	0.081	340.94	5.36	6.24	0.043
LDNO HVplus: HV Site Specific Band 2		0	1.204	0.209	0.081	1648.75	5.36	6.24	0.043

Tariff name	Unique billing identifier	PCs	Red/black unit charge p/kWh	Amber/yellow unit charge p/kWh	Green unit charge p/kWh	Fixed charge p/MPAN/day	Capacity charge p/kVA/day	Exceeded capacity charge p/kVA/day	Reactive power charge p/kVArh
LDNO HVplus: HV Site Specific Band 3		0	1.204	0.209	0.081	3375.89	5.36	6.24	0.043
LDNO HVplus: HV Site Specific Band 4		0	1.204	0.209	0.081	7236.65	5.36	6.24	0.043
LDNO HVplus: Unmetered Supplies		0, 1 or 8	5.265	1.479	1.186				
LDNO HVplus: LV Generation Aggregated		0 or 8	-2.870	-0.597	-0.208	0.00			
LDNO HVplus: LV Sub Generation Aggregated		0 or 8	-2.787	-0.573	-0.200	0.00			
LDNO HVplus: LV Generation Site Specific		0	-2.870	-0.597	-0.208	0.00			0.120
LDNO HVplus: LV Sub Generation Site Specific		0	-2.787	-0.573	-0.200	0.00			0.109
LDNO HVplus: HV Generation Site Specific		0	-3.399	-0.615	-0.224	526.70			0.216
LDNO EHV: Domestic Aggregated with Residual		0, 1, 2	1.640	0.341	0.119	13.22			
LDNO EHV: Domestic Aggregated (Related MPAN)		2	1.640	0.341	0.119				
LDNO EHV: Non-Domestic Aggregated No Residual		0, 3, 4, 5-8	1.882	0.391	0.136	1.98			
LDNO EHV: Non-Domestic Aggregated Band 1		0, 3, 4, 5-8	1.882	0.391	0.136	2.55			
LDNO EHV: Non-Domestic Aggregated Band 2		0, 3, 4, 5-8	1.882	0.391	0.136	5.32			

Tariff name	Unique billing identifier	PCs	Red/black unit charge p/kWh	Amber/yellow unit charge p/kWh	Green unit charge p/kWh	Fixed charge p/MPAN/day	Capacity charge p/kVA/day	Exceeded capacity charge p/kVA/day	Reactive power charge p/kVArh
LDNO EHV: Non-Domestic Aggregated Band 3		0, 3, 4, 5-8	1.882	0.391	0.136	10.21			
LDNO EHV: Non-Domestic Aggregated Band 4		0, 3, 4, 5-8	1.882	0.391	0.136	28.90			
LDNO EHV: Non-Domestic Aggregated (related MPAN)		4	1.882	0.391	0.136				
LDNO EHV: LV Site Specific No Residual		0	1.356	0.275	0.096	5.13	1.02	1.78	0.054
LDNO EHV: LV Site Specific Band 1		0	1.356	0.275	0.096	47.48	1.02	1.78	0.054
LDNO EHV: LV Site Specific Band 2		0	1.356	0.275	0.096	84.87	1.02	1.78	0.054
LDNO EHV: LV Site Specific Band 3		0	1.356	0.275	0.096	138.03	1.02	1.78	0.054
LDNO EHV: LV Site Specific Band 4		0	1.356	0.275	0.096	315.87	1.02	1.78	0.054
LDNO EHV: LV Sub Site Specific No Residual		0	0.983	0.178	0.065	16.80	2.27	3.07	0.036
LDNO EHV: LV Sub Site Specific Band 1		0	0.983	0.178	0.065	76.18	2.27	3.07	0.036
LDNO EHV: LV Sub Site Specific Band 2		0	0.983	0.178	0.065	128.61	2.27	3.07	0.036
LDNO EHV: LV Sub Site Specific Band 3		0	0.983	0.178	0.065	203.15	2.27	3.07	0.036
LDNO EHV: LV Sub Site Specific Band 4		0	0.983	0.178	0.065	452.52	2.27	3.07	0.036

Tariff name	Unique billing identifier	PCs	Red/black unit charge p/kWh	Amber/yellow unit charge p/kWh	Green unit charge p/kWh	Fixed charge p/MPAN/day	Capacity charge p/kVA/day	Exceeded capacity charge p/kVA/day	Reactive power charge p/kVArh
LDNO EHV: HV Site Specific No Residual		0	0.746	0.129	0.050	91.73	3.32	3.86	0.027
LDNO EHV: HV Site Specific Band 1		0	0.746	0.129	0.050	211.16	3.32	3.86	0.027
LDNO EHV: HV Site Specific Band 2		0	0.746	0.129	0.050	1021.09	3.32	3.86	0.027
LDNO EHV: HV Site Specific Band 3		0	0.746	0.129	0.050	2090.71	3.32	3.86	0.027
LDNO EHV: HV Site Specific Band 4		0	0.746	0.129	0.050	4481.67	3.32	3.86	0.027
LDNO EHV: Unmetered Supplies		0, 1 or 8	3.261	0.916	0.735				
LDNO EHV: LV Generation Aggregated		0 or 8	-1.778	-0.370	-0.129	0.00			
LDNO EHV: LV Sub Generation Aggregated		0 or 8	-1.726	-0.355	-0.124	0.00			
LDNO EHV: LV Generation Site Specific		0	-1.778	-0.370	-0.129	0.00			0.075
LDNO EHV: LV Sub Generation Site Specific		0	-1.726	-0.355	-0.124	0.00			0.068
LDNO EHV: HV Generation Site Specific		0	-2.105	-0.381	-0.138	326.18			0.134
LDNO 132kV/EHV: Domestic Aggregated with Residual		0, 1, 2	0.621	0.129	0.045	11.17			
LDNO 132kV/EHV: Domestic Aggregated (Related MPAN)		2	0.621	0.129	0.045				

Tariff name	Unique billing identifier	PCs	Red/black unit charge p/kWh	Amber/yellow unit charge p/kWh	Green unit charge p/kWh	Fixed charge p/MPAN/day	Capacity charge p/kVA/day	Exceeded capacity charge p/kVA/day	Reactive power charge p/kVArh
LDNO 132kV/EHV: Non-Domestic Aggregated No Residual		0, 3, 4, 5-8	0.712	0.148	0.052	0.78			
LDNO 132kV/EHV: Non-Domestic Aggregated Band 1		0, 3, 4, 5-8	0.712	0.148	0.052	0.99			
LDNO 132kV/EHV: Non-Domestic Aggregated Band 2		0, 3, 4, 5-8	0.712	0.148	0.052	2.04			
LDNO 132kV/EHV: Non-Domestic Aggregated Band 3		0, 3, 4, 5-8	0.712	0.148	0.052	3.89			
LDNO 132kV/EHV: Non-Domestic Aggregated Band 4		0, 3, 4, 5-8	0.712	0.148	0.052	10.97			
LDNO 132kV/EHV: Non-Domestic Aggregated (related MPAN)		4	0.712	0.148	0.052				
LDNO 132kV/EHV: LV Site Specific No Residual		0	0.513	0.104	0.036	1.97	0.39	0.67	0.021
LDNO 132kV/EHV: LV Site Specific Band 1		0	0.513	0.104	0.036	18.00	0.39	0.67	0.021
LDNO 132kV/EHV: LV Site Specific Band 2		0	0.513	0.104	0.036	32.15	0.39	0.67	0.021
LDNO 132kV/EHV: LV Site Specific Band 3		0	0.513	0.104	0.036	52.26	0.39	0.67	0.021
LDNO 132kV/EHV: LV Site Specific Band 4		0	0.513	0.104	0.036	119.55	0.39	0.67	0.021
LDNO 132kV/EHV: LV Sub Site Specific No Residual		0	0.372	0.067	0.024	6.39	0.86	1.16	0.014
LDNO 132kV/EHV: LV Sub Site Specific Band 1		0	0.372	0.067	0.024	28.86	0.86	1.16	0.014

Tariff name	Unique billing identifier	PCs	Red/black unit charge p/kWh	Amber/yellow unit charge p/kWh	Green unit charge p/kWh	Fixed charge p/MPAN/day	Capacity charge p/kVA/day	Exceeded capacity charge p/kVA/day	Reactive power charge p/kVArh
LDNO 132kV/EHV: LV Sub Site Specific Band 2		0	0.372	0.067	0.024	48.70	0.86	1.16	0.014
LDNO 132kV/EHV: LV Sub Site Specific Band 3		0	0.372	0.067	0.024	76.90	0.86	1.16	0.014
LDNO 132kV/EHV: LV Sub Site Specific Band 4		0	0.372	0.067	0.024	171.26	0.86	1.16	0.014
LDNO 132kV/EHV: HV Site Specific No Residual		0	0.282	0.049	0.019	34.74	1.26	1.46	0.010
LDNO 132kV/EHV: HV Site Specific Band 1		0	0.282	0.049	0.019	79.93	1.26	1.46	0.010
LDNO 132kV/EHV: HV Site Specific Band 2		0	0.282	0.049	0.019	386.41	1.26	1.46	0.010
LDNO 132kV/EHV: HV Site Specific Band 3		0	0.282	0.049	0.019	791.15	1.26	1.46	0.010
LDNO 132kV/EHV: HV Site Specific Band 4		0	0.282	0.049	0.019	1695.89	1.26	1.46	0.010
LDNO 132kV/EHV: Unmetered Supplies		0, 1 or 8	1.234	0.346	0.278				
LDNO 132kV/EHV: LV Generation Aggregated		0 or 8	-0.673	-0.140	-0.049	0.00			
LDNO 132kV/EHV: LV Sub Generation Aggregated		0 or 8	-0.653	-0.134	-0.047	0.00			
LDNO 132kV/EHV: LV Generation Site Specific		0	-0.673	-0.140	-0.049	0.00			0.028
LDNO 132kV/EHV: LV Sub Generation Site Specific		0	-0.653	-0.134	-0.047	0.00			0.026

Tariff name	Unique billing identifier	PCs	Red/black unit charge p/kWh	Amber/yellow unit charge p/kWh	Green unit charge p/kWh	Fixed charge p/MPAN/day	Capacity charge p/kVA/day	Exceeded capacity charge p/kVA/day	Reactive power charge p/kVArh
LDNO 132kV/EHV: HV Generation Site Specific		0	-0.797	-0.144	-0.052	123.43			0.051
LDNO 132kV: Domestic Aggregated with Residual		0, 1, 2	0.526	0.109	0.038	10.98			
LDNO 132kV: Domestic Aggregated (Related MPAN)		2	0.526	0.109	0.038				
LDNO 132kV: Non-Domestic Aggregated No Residual		0, 3, 4, 5-8	0.603	0.125	0.044	0.67			
LDNO 132kV: Non-Domestic Aggregated Band 1		0, 3, 4, 5-8	0.603	0.125	0.044	0.85			
LDNO 132kV: Non-Domestic Aggregated Band 2		0, 3, 4, 5-8	0.603	0.125	0.044	1.74			
LDNO 132kV: Non-Domestic Aggregated Band 3		0, 3, 4, 5-8	0.603	0.125	0.044	3.31			
LDNO 132kV: Non-Domestic Aggregated Band 4		0, 3, 4, 5-8	0.603	0.125	0.044	9.30			
LDNO 132kV: Non-Domestic Aggregated (related MPAN)		4	0.603	0.125	0.044				
LDNO 132kV: LV Site Specific No Residual		0	0.435	0.088	0.031	1.68	0.33	0.57	0.017
LDNO 132kV: LV Site Specific Band 1		0	0.435	0.088	0.031	15.25	0.33	0.57	0.017
LDNO 132kV: LV Site Specific Band 2		0	0.435	0.088	0.031	27.24	0.33	0.57	0.017
LDNO 132kV: LV Site Specific Band 3		0	0.435	0.088	0.031	44.28	0.33	0.57	0.017

Tariff name	Unique billing identifier	PCs	Red/black unit charge p/kWh	Amber/yellow unit charge p/kWh	Green unit charge p/kWh	Fixed charge p/MPAN/day	Capacity charge p/kVA/day	Exceeded capacity charge p/kVA/day	Reactive power charge p/kVArh
LDNO 132kV: LV Site Specific Band 4		0	0.435	0.088	0.031	101.28	0.33	0.57	0.017
LDNO 132kV: LV Sub Site Specific No Residual		0	0.315	0.057	0.021	5.42	0.73	0.98	0.012
LDNO 132kV: LV Sub Site Specific Band 1		0	0.315	0.057	0.021	24.45	0.73	0.98	0.012
LDNO 132kV: LV Sub Site Specific Band 2		0	0.315	0.057	0.021	41.26	0.73	0.98	0.012
LDNO 132kV: LV Sub Site Specific Band 3		0	0.315	0.057	0.021	65.15	0.73	0.98	0.012
LDNO 132kV: LV Sub Site Specific Band 4		0	0.315	0.057	0.021	145.08	0.73	0.98	0.012
LDNO 132kV: HV Site Specific No Residual		0	0.239	0.041	0.016	29.44	1.06	1.24	0.009
LDNO 132kV: HV Site Specific Band 1		0	0.239	0.041	0.016	67.72	1.06	1.24	0.009
LDNO 132kV: HV Site Specific Band 2		0	0.239	0.041	0.016	327.32	1.06	1.24	0.009
LDNO 132kV: HV Site Specific Band 3		0	0.239	0.041	0.016	670.17	1.06	1.24	0.009
LDNO 132kV: HV Site Specific Band 4		0	0.239	0.041	0.016	1436.54	1.06	1.24	0.009
LDNO 132kV: Unmetered Supplies		0, 1 or 8	1.045	0.293	0.235				
LDNO 132kV: LV Generation Aggregated		0 or 8	-0.570	-0.118	-0.041	0.00			

Tariff name	Unique billing identifier	PCs	Red/black unit charge p/kWh	Amber/yellow unit charge p/kWh	Green unit charge p/kWh	Fixed charge p/MPAN/day	Capacity charge p/kVA/day	Exceeded capacity charge p/kVA/day	Reactive power charge p/kVArh
LDNO 132kV: LV Sub Generation Aggregated		0 or 8	-0.553	-0.114	-0.040	0.00			
LDNO 132kV: LV Generation Site Specific		0	-0.570	-0.118	-0.041	0.00			0.024
LDNO 132kV: LV Sub Generation Site Specific		0	-0.553	-0.114	-0.040	0.00			0.022
LDNO 132kV: HV Generation Site Specific		0	-0.675	-0.122	-0.044	104.55			0.043
LDNO 0000: Domestic Aggregated with Residual		0, 1, 2	0.526	0.109	0.038	10.98			
LDNO 0000: Domestic Aggregated (Related MPAN)		2	0.526	0.109	0.038				
LDNO 0000: Non-Domestic Aggregated No Residual		0, 3, 4, 5-8	0.603	0.125	0.044	0.67			
LDNO 0000: Non-Domestic Aggregated Band 1		0, 3, 4, 5-8	0.603	0.125	0.044	0.85			
LDNO 0000: Non-Domestic Aggregated Band 2		0, 3, 4, 5-8	0.603	0.125	0.044	1.74			
LDNO 0000: Non-Domestic Aggregated Band 3		0, 3, 4, 5-8	0.603	0.125	0.044	3.31			
LDNO 0000: Non-Domestic Aggregated Band 4		0, 3, 4, 5-8	0.603	0.125	0.044	9.30			
LDNO 0000: Non-Domestic Aggregated (related MPAN)		4	0.603	0.125	0.044				
LDNO 0000: LV Site Specific No Residual		0	0.435	0.088	0.031	1.68	0.33	0.57	0.017

Tariff name	Unique billing identifier	PCs	Red/black unit charge p/kWh	Amber/yellow unit charge p/kWh	Green unit charge p/kWh	Fixed charge p/MPAN/day	Capacity charge p/kVA/day	Exceeded capacity charge p/kVA/day	Reactive power charge p/kVArh
LDNO 0000: LV Site Specific Band 1		0	0.435	0.088	0.031	15.25	0.33	0.57	0.017
LDNO 0000: LV Site Specific Band 2		0	0.435	0.088	0.031	27.24	0.33	0.57	0.017
LDNO 0000: LV Site Specific Band 3		0	0.435	0.088	0.031	44.28	0.33	0.57	0.017
LDNO 0000: LV Site Specific Band 4		0	0.435	0.088	0.031	101.28	0.33	0.57	0.017
LDNO 0000: LV Sub Site Specific No Residual		0	0.315	0.057	0.021	5.42	0.73	0.98	0.012
LDNO 0000: LV Sub Site Specific Band 1		0	0.315	0.057	0.021	24.45	0.73	0.98	0.012
LDNO 0000: LV Sub Site Specific Band 2		0	0.315	0.057	0.021	41.26	0.73	0.98	0.012
LDNO 0000: LV Sub Site Specific Band 3		0	0.315	0.057	0.021	65.15	0.73	0.98	0.012
LDNO 0000: LV Sub Site Specific Band 4		0	0.315	0.057	0.021	145.08	0.73	0.98	0.012
LDNO 0000: HV Site Specific No Residual		0	0.239	0.041	0.016	29.44	1.06	1.24	0.009
LDNO 0000: HV Site Specific Band 1		0	0.239	0.041	0.016	67.72	1.06	1.24	0.009
LDNO 0000: HV Site Specific Band 2		0	0.239	0.041	0.016	327.32	1.06	1.24	0.009
LDNO 0000: HV Site Specific Band 3		0	0.239	0.041	0.016	670.17	1.06	1.24	0.009

Tariff name	Unique billing identifier	PCs	Red/black unit charge p/kWh	Amber/yellow unit charge p/kWh	Green unit charge p/kWh	Fixed charge p/MPAN/day	Capacity charge p/kVA/day	Exceeded capacity charge p/kVA/day	Reactive power charge p/kVArh
LDNO 0000: HV Site Specific Band 4		0	0.239	0.041	0.016	1436.54	1.06	1.24	0.009
LDNO 0000: Unmetered Supplies		0, 1 or 8	1.045	0.293	0.235				
LDNO 0000: LV Generation Aggregated		0 or 8	-0.570	-0.118	-0.041	0.00			
LDNO 0000: LV Sub Generation Aggregated		0 or 8	-0.553	-0.114	-0.040	0.00			
LDNO 0000: LV Generation Site Specific		0	-0.570	-0.118	-0.041	0.00			0.024
LDNO 0000: LV Sub Generation Site Specific		0	-0.553	-0.114	-0.040	0.00			0.022
LDNO 0000: HV Generation Site Specific		0	-0.675	-0.122	-0.044	104.55			0.043

Annex 5 – Schedule of Line Loss Factors

LLF time periods:

Scottish Hydro Electric Power Distribution plc - LLFs Effective from 1st April 2022				
Time periods	Period 1	Period 2	Period 3	Period 4
	Winter Weekday Peak	Winter Weekday	Other	Night
Monday to Friday Nov to Feb	16:00 – 19:00	07:30 – 16:00 19:00 – 20:00	20:00 - 00:30	00:30 – 07:30
Saturday to Sunday All Year and Monday to Friday Mar to Oct			07:30 - 00:30	00:30 – 07:30
Notes	All the above times are in UK Clock time			

Generic demand and generation LLFs					
Metered voltage, respective periods and associated LLFCs					
Metered voltage	Period 1	Period 2	Period 3	Period 4	Associated LLFC
Low-voltage network	1.093	1.094	1.098	1.102	15-20, 22, 24-28, 30-31, 100-102, 104-106, 110, 111, 120-122, 124-128, 152, 155, 172, 175, 300-302, 304-305, 320-322, 324-325, 352, 355, 372, 375, 506, 800-805, P00-P84, R35-R99, S00-S04, S10-S14 / 1, 2, 9, 10, 909, 951
Low-voltage substation	1.063	1.064	1.073	1.076	32, S05-S09, P85-P89 / 3, 4, 11, 12, 952
High-voltage network	1.037	1.037	1.036	1.037	604, P90-P94, S15-S24 / 5, 6, 13, 14, 910
High-voltage substation	1.027	1.027	1.027	1.028	560-569, 578, 586-589, 591-599 / 520-530, 535-554
33kV generic	1.014	1.014	1.009	1.009	799 / 960
132/33kV generic					
132kV generic					

EHV site specific LLFs					
Demand					
Site	Period 1	Period 2	Period 3	Period 4	Associated LLFC
Tariff 001	1.027	1.027	1.027	1.028	595
Tariff 002	1.027	1.027	1.027	1.028	596
Tariff 003	1.027	1.027	1.027	1.028	597
Tariff 004	1.027	1.027	1.027	1.028	598
Tariff 005	1.027	1.027	1.027	1.028	560
Tariff 006	1.027	1.027	1.027	1.028	560
Tariff 008	1.027	1.027	1.027	1.028	562
Tariff 009	1.027	1.027	1.027	1.028	562

EHV site specific LLFs					
Demand					
Site	Period 1	Period 2	Period 3	Period 4	Associated LLFC
Tariff 010	1.027	1.027	1.027	1.028	562
Tariff 011	1.027	1.027	1.027	1.028	563
Tariff 012	1.027	1.027	1.027	1.028	564
Tariff 013	1.027	1.027	1.027	1.028	565
Tariff 014	1.027	1.027	1.027	1.028	566
Tariff 015	1.027	1.027	1.027	1.028	567
Tariff 016	1.027	1.027	1.027	1.028	569
Tariff 017	1.000	1.000	1.000	1.000	713
Tariff 018	1.004	1.003	1.004	1.004	714
Tariff 020	1.000	1.000	1.000	1.000	8707
Tariff 021	1.039	1.043	1.039	1.044	717
Tariff 022	1.007	1.008	1.008	1.007	718
Tariff 023	1.000	1.000	1.000	1.000	637
Tariff 024	0.991	0.990	0.990	0.990	8328
Tariff 025	1.013	1.015	1.022	1.019	722
Tariff 026	0.983	0.983	0.982	0.983	8696
Tariff 027	1.002	1.002	1.002	1.002	723
Tariff 028	1.020	1.020	1.019	1.019	724
Tariff 029	1.000	1.000	1.000	1.000	725
Tariff 030	1.000	1.000	1.000	1.000	726
Tariff 031	0.992	0.992	0.992	0.992	8699
Tariff 032	0.992	0.992	0.992	0.992	8699
Tariff 033	1.008	1.009	1.012	1.011	727
Tariff 035	1.002	1.002	1.002	1.002	730
Tariff 036	1.002	1.002	1.002	1.002	731
Tariff 037	1.003	1.003	1.003	1.002	732
Tariff 038	1.000	1.000	1.000	1.000	787
Tariff 039	N/A	N/A	N/A	N/A	8688
Tariff 040	1.000	1.000	1.000	1.000	735
Tariff 041	1.000	1.000	1.000	1.000	736
Tariff 042	1.035	1.034	1.049	1.050	737
Tariff 043	1.008	1.008	1.007	1.006	738
Tariff 044	1.009	1.008	1.009	1.008	739
Tariff 045	1.001	1.001	1.001	1.001	740
Tariff 046	1.036	1.041	1.037	1.041	741
Tariff 047	0.997	0.998	0.997	0.998	742
Tariff 048	1.000	1.000	1.000	1.000	743
Tariff 049	1.010	1.015	1.015	1.018	744
Tariff 050	1.064	1.061	1.077	1.088	745
Tariff 051	1.065	1.072	1.075	1.093	746
Tariff 052	1.000	1.001	0.998	0.996	748
Tariff 053	1.121	1.122	1.133	1.115	749
Tariff 054	0.996	0.999	0.996	0.997	753
Tariff 055	1.011	1.013	1.023	1.023	754
Tariff 057	0.942	0.943	0.953	0.951	756
Tariff 058	1.002	1.002	1.002	1.002	758
Tariff 059	1.027	1.027	1.027	1.028	589
Tariff 060	1.075	1.121	1.143	1.144	761
Tariff 061	0.962	0.961	0.961	0.960	8694
Tariff 062	0.962	0.961	0.961	0.960	8694
Tariff 063	1.000	1.000	1.000	1.000	762
Tariff 064	1.022	1.021	1.039	1.039	763
Tariff 065	1.007	1.008	1.007	1.008	767

EHV site specific LLFs					
Demand					
Site	Period 1	Period 2	Period 3	Period 4	Associated LLFC
Tariff 067	1.002	1.003	1.003	1.004	769
Tariff 068	N/A	N/A	N/A	N/A	8687
Tariff 069	1.002	1.002	1.003	1.003	772
Tariff 070	0.984	0.984	0.985	0.984	773
Tariff 071	0.983	0.983	0.982	0.982	774
Tariff 072	1.000	1.000	1.000	1.000	633
Tariff 073	1.000	1.000	1.000	1.000	775
Tariff 074	0.910	0.911	0.920	0.917	777
Tariff 075	1.000	1.000	1.000	1.000	779
Tariff 079	1.005	1.007	1.007	1.006	783
Tariff 080	1.005	1.007	1.007	1.006	784
Tariff 082	1.011	1.011	1.011	1.010	786
Tariff 083	N/A	N/A	N/A	N/A	8689
Tariff 084	N/A	N/A	N/A	N/A	8689
Tariff 085	1.012	1.012	1.011	1.011	789
Tariff 086	0.973	0.973	0.972	0.973	791
Tariff 087	0.978	0.976	0.975	0.975	8740
Tariff 088	1.019	1.020	1.021	1.019	607
Tariff 089	1.000	1.000	1.000	1.000	608
Tariff 090	1.058	1.057	1.057	1.044	729
Tariff 091	1.149	1.140	1.156	1.141	609
Tariff 093	1.007	1.021	1.019	1.019	610
Tariff 094	1.027	1.027	1.023	1.025	611
Tariff 095	1.260	1.266	1.293	1.310	612
Tariff 096	0.985	0.986	0.994	0.979	613
Tariff 097	1.014	1.016	1.014	1.012	614
Tariff 098	1.022	1.019	1.019	1.016	615
Tariff 099	1.000	1.000	1.000	1.000	703
Tariff 100	1.013	1.017	1.023	1.021	704
Tariff 101	1.011	1.011	1.010	1.010	705
Tariff 102	1.015	1.015	1.015	1.013	706
Tariff 103	1.009	1.009	1.009	1.009	707
Tariff 104	1.000	1.000	1.000	1.000	708
Tariff 106	1.004	1.007	1.006	1.003	710
Tariff 107	1.000	1.000	1.000	1.000	711
Tariff 108	1.001	1.002	1.002	1.002	685
Tariff 109	1.000	1.000	1.000	1.000	686
Tariff 110	1.005	1.005	1.005	1.005	687
Tariff 111	1.022	1.024	1.024	1.023	688
Tariff 112	1.000	1.000	1.000	1.000	638
Tariff 122	1.000	1.000	1.000	1.000	689
Tariff 123	1.000	1.000	1.000	1.000	689
Tariff 124	1.000	1.000	1.000	1.000	689
Tariff 125	1.000	1.000	1.000	1.000	689
Tariff 126	1.000	1.000	1.000	1.000	690
Tariff 127	1.000	1.000	1.000	1.000	690
Tariff 128	1.010	1.008	1.008	1.007	616
Tariff 129	1.010	1.008	1.006	1.006	617
Tariff 130	1.058	1.056	1.052	1.052	618
Tariff 131	1.029	1.028	1.026	1.027	619
Tariff 132	0.980	0.981	0.981	0.981	620
Tariff 133	1.045	1.061	1.071	1.067	621
Tariff 134	1.000	1.000	1.000	1.000	622

EHV site specific LLFs					
Demand					
Site	Period 1	Period 2	Period 3	Period 4	Associated LLFC
Tariff 135	1.093	1.145	1.175	1.173	623
Tariff 136	1.008	1.010	1.010	1.009	625
Tariff 137	1.002	1.002	1.002	1.002	626
Tariff 138	1.000	1.000	1.000	1.000	766
Tariff 140	1.000	1.000	1.000	1.000	793
Tariff 141	0.998	0.998	0.998	0.998	630
Tariff 143	0.992	0.992	0.992	0.992	634
Tariff 144	1.013	1.014	1.014	1.013	635
Tariff 146	0.985	0.985	0.985	0.985	790
Tariff 147	0.996	0.996	0.996	0.996	644
Tariff 149	1.027	1.024	1.024	1.020	646
Tariff 150	0.967	0.967	0.967	0.967	648
Tariff 151	0.994	0.994	0.993	0.994	8715
Tariff 153	0.950	0.950	0.950	0.950	652
Tariff 154	1.004	1.004	1.003	1.003	653
Tariff 155	1.000	1.000	1.000	1.000	654
Tariff 157	1.017	1.017	1.017	1.015	795
Tariff 158	0.943	0.940	0.937	0.937	796
Tariff 159	1.018	1.017	1.015	1.015	797
Tariff 161	1.000	1.000	1.000	1.000	658
Tariff 162	1.011	1.017	1.017	1.019	655
Tariff 163	1.000	1.000	1.000	1.000	659
Tariff 165	1.241	1.238	1.237	1.211	661
Tariff 166	1.004	1.003	1.003	1.002	624
Tariff 170	0.988	0.988	0.988	0.988	664
Tariff 171	1.000	1.000	1.000	1.000	665
Tariff 172	1.128	1.127	1.148	1.115	778
Tariff 174	1.008	1.007	1.007	1.006	667
Tariff 177	1.000	1.000	1.000	1.000	691
Tariff 178	1.000	1.000	1.000	1.000	691
Tariff 191	0.997	0.998	0.994	0.994	668
Tariff 192	0.983	1.010	0.983	0.986	669
Tariff 194	1.000	1.000	1.000	1.000	780
Tariff 196	1.010	1.011	1.011	1.011	673
Tariff 197	0.999	0.999	0.999	0.999	647
Tariff 200	1.128	1.164	1.212	1.197	583
Tariff 202	1.000	1.001	1.001	1.000	675
Tariff 203	1.005	1.032	1.056	1.032	676
Tariff 204	1.020	1.021	1.018	1.019	677
Tariff 206	1.000	0.999	0.998	0.998	679
Tariff 207	1.006	1.005	1.006	1.004	680
Tariff 208	0.997	0.997	0.997	0.997	681
Tariff 209	0.959	0.958	0.956	0.957	682
Tariff 212	1.003	1.003	1.003	1.003	692
Tariff 214	1.119	1.122	1.115	1.108	694
Tariff 215	0.996	0.996	0.996	0.996	8720
Tariff 216	0.979	0.979	0.979	0.979	696
Tariff 217	0.972	0.972	0.972	0.972	697
Tariff 221	1.069	1.056	1.069	1.069	656
Tariff 228	1.001	1.001	1.001	1.001	577
Tariff 230	0.977	0.977	0.976	0.976	8719
Tariff 232	1.013	1.013	1.012	1.012	581
Tariff 234	1.054	1.051	1.048	1.051	631

EHV site specific LLFs					
Demand					
Site	Period 1	Period 2	Period 3	Period 4	Associated LLFC
Tariff 235	1.014	1.017	1.014	1.016	636
Tariff 237	1.019	1.017	1.018	1.015	771
Tariff 238	1.000	1.000	1.000	1.000	8707
Tariff 239	1.083	1.095	1.113	1.128	750
Tariff 240	0.999	0.999	0.999	1.000	628
Tariff 241	1.007	1.007	1.007	1.008	781
Tariff 242	1.000	1.000	1.000	1.000	639
Tariff 246	0.996	0.996	0.996	0.996	8722
Tariff 249	1.000	1.000	1.000	1.000	570
Tariff 251	0.954	0.955	0.955	0.954	576
Tariff 252	0.967	0.967	0.967	0.967	580
Tariff 253	1.009	1.006	1.011	1.008	640
Tariff 254	0.947	0.946	0.946	0.947	629
Tariff 255	0.966	0.966	0.966	0.966	8741
Tariff 256	1.004	1.004	1.004	1.003	641
Tariff 257	1.000	1.000	1.000	1.000	782
Tariff 258	1.006	1.007	1.006	1.006	590
Tariff 259	0.977	0.978	0.977	0.978	645
Tariff 260	1.016	1.015	1.015	1.014	649
Tariff 262	0.970	0.970	0.970	0.970	792
Tariff 263	1.091	1.091	1.094	1.094	734
Tariff 265	1.029	1.027	1.027	1.026	693
Tariff 266	1.014	1.014	1.009	1.009	799
Tariff 269	1.021	1.021	1.025	1.023	695
Tariff 273	1.011	1.010	1.011	1.009	764
Tariff 274	1.000	1.000	1.000	1.000	627
Tariff 277	0.975	0.982	0.980	0.986	698
Tariff 282	1.009	1.017	1.018	1.018	666
Tariff 286	0.981	0.982	0.981	0.980	642
Tariff 287	1.002	1.002	1.002	1.002	699
Tariff 288	0.966	0.966	0.966	0.966	8727
Tariff 289	0.964	0.963	0.963	0.963	702
Tariff 290	1.001	1.001	1.002	1.002	712
Tariff 291	1.007	1.009	1.008	1.008	794
Tariff 292	1.022	1.025	1.022	1.020	716
Tariff 295	1.007	1.006	1.006	1.005	719
Tariff 296	1.016	1.015	1.014	1.010	765
Tariff 299	0.985	0.985	0.985	0.985	585
Tariff 300	1.014	1.014	1.009	1.009	799
Tariff 302	1.019	1.017	1.022	1.020	776
Tariff 303	1.020	1.017	1.022	1.020	657
Tariff 311	1.002	1.011	1.004	1.014	594
Tariff 312	0.999	0.999	0.999	0.999	747
Tariff 317	0.997	1.000	1.000	0.999	757
Tariff 320	1.000	1.000	1.000	1.000	672
Tariff 322	1.000	1.000	1.000	1.000	768
Tariff 327	1.000	1.000	1.000	1.000	674
Tariff 331	1.000	1.000	1.000	1.000	728
Tariff 334	0.993	0.995	0.996	0.995	751
Tariff 340	1.000	1.000	1.000	1.000	720
Tariff 342	1.000	1.000	1.000	1.000	8752
Tariff 348	1.014	1.023	1.011	1.010	788
Tariff 350	1.014	1.014	1.009	1.009	799

EHV site specific LLFs					
Demand					
Site	Period 1	Period 2	Period 3	Period 4	Associated LLFC
Tariff 355	1.022	1.025	1.022	1.020	721
Tariff 356	1.000	1.000	1.000	1.000	798
Tariff 357	1.020	1.018	1.018	1.015	670
Tariff 358	1.029	1.025	1.033	1.030	759
Tariff 359	1.007	1.006	1.007	1.005	671
Tariff 362	1.000	1.000	1.000	1.000	785
Tariff 363	0.998	1.002	1.001	0.998	643
Tariff 364	1.000	1.000	1.000	1.000	760
Tariff 365	1.000	1.000	1.000	1.000	572
Tariff 367	1.000	1.000	1.000	1.000	8743
Tariff 369	1.000	1.000	1.018	1.000	591
Tariff 372	0.991	0.991	0.991	0.991	663
Tariff 375	1.014	1.014	1.009	1.009	799
Tariff 377	0.981	0.981	0.983	0.983	683
Tariff 379	0.933	0.936	0.934	0.935	733
Tariff 380	0.970	0.970	0.970	0.970	752
Tariff 381	1.000	1.000	1.000	1.000	573
Tariff 382	1.025	1.025	1.023	1.023	770
Tariff 383	1.014	1.014	1.009	1.009	799
Tariff 384	1.009	1.009	1.010	1.009	592
Tariff 387	1.027	1.024	1.024	1.020	700
Tariff 389	1.043	1.065	1.347	1.060	593
Tariff 390	1.014	1.014	1.009	1.009	799
Tariff 392	1.027	1.027	1.027	1.028	568
Tariff 393	1.014	1.014	1.009	1.009	799
Tariff 396	1.014	1.014	1.009	1.009	799
Tariff 416	1.010	1.009	1.010	1.008	584
Tariff 426	1.014	1.014	1.009	1.009	799
Tariff 433	1.014	1.014	1.009	1.009	799
Tariff 434	1.014	1.014	1.009	1.009	799
Tariff 436	1.014	1.014	1.009	1.009	799
Tariff 439	1.014	1.014	1.009	1.009	799
Tariff 440	1.014	1.014	1.009	1.009	8760
Tariff 443	1.014	1.014	1.009	1.009	799
Tariff 444	1.014	1.014	1.009	1.009	799
Tariff 445	1.014	1.014	1.009	1.009	799
Tariff 446	1.014	1.014	1.009	1.009	799
Tariff 447	1.014	1.014	1.009	1.009	799
Tariff 448	1.014	1.014	1.009	1.009	799
Tariff 449	1.014	1.014	1.009	1.009	799
Tariff 450	1.014	1.014	1.009	1.009	799

EHV site specific LLFs					
Generation					
Site	Period 1	Period 2	Period 3	Period 4	Associated LLFC
Tariff 004	1.027	1.027	1.027	1.028	530
Tariff 005	1.027	1.027	1.027	1.028	520
Tariff 006	1.027	1.027	1.027	1.028	520
Tariff 008	1.027	1.027	1.027	1.028	522
Tariff 009	1.027	1.027	1.027	1.028	522
Tariff 010	1.027	1.027	1.027	1.028	522

EHV site specific LLFs					
Generation					
Site	Period 1	Period 2	Period 3	Period 4	Associated LLFC
Tariff 011	1.027	1.027	1.027	1.028	523
Tariff 012	1.027	1.027	1.027	1.028	524
Tariff 013	1.027	1.027	1.027	1.028	525
Tariff 014	1.027	1.027	1.027	1.028	526
Tariff 015	1.027	1.027	1.027	1.028	527
Tariff 017	0.998	0.998	0.999	0.998	913
Tariff 018	0.999	0.999	0.999	0.999	914
Tariff 019	0.999	0.999	0.999	0.999	915
Tariff 020	1.000	1.000	1.000	1.000	8707
Tariff 021	1.027	1.031	1.027	1.032	917
Tariff 022	1.002	1.003	1.003	1.003	918
Tariff 023	0.997	0.997	0.997	0.997	837
Tariff 024	0.991	0.990	0.990	0.990	8328
Tariff 025	1.013	1.016	1.025	1.019	922
Tariff 026	0.983	0.983	0.982	0.983	8696
Tariff 027	0.992	0.992	0.992	0.992	923
Tariff 028	1.014	1.014	1.013	1.013	924
Tariff 029	0.995	0.995	0.995	0.996	925
Tariff 030	0.990	0.990	0.990	0.990	926
Tariff 031	0.992	0.992	0.992	0.992	8699
Tariff 032	0.992	0.992	0.992	0.992	8699
Tariff 033	0.985	0.986	0.989	0.988	927
Tariff 035	1.000	1.000	1.000	1.000	930
Tariff 036	1.000	1.000	1.000	1.001	931
Tariff 037	0.995	0.992	0.991	0.994	932
Tariff 038	0.998	0.998	0.998	0.998	987
Tariff 039	N/A	N/A	N/A	N/A	8688
Tariff 040	1.000	1.000	1.000	1.000	935
Tariff 041	1.000	1.000	1.000	1.000	936
Tariff 042	1.027	1.027	1.044	1.044	937
Tariff 043	1.000	1.000	0.999	0.998	938
Tariff 044	1.000	1.000	1.000	0.999	939
Tariff 045	0.965	0.964	0.963	0.964	940
Tariff 046	1.024	1.029	1.025	1.028	941
Tariff 047	0.993	0.994	0.993	0.993	942
Tariff 048	1.000	1.000	1.000	1.000	943
Tariff 049	0.990	0.994	0.994	0.996	944
Tariff 050	0.998	0.997	0.997	0.996	945
Tariff 051	0.996	0.995	0.995	0.993	946
Tariff 052	0.977	0.978	0.975	0.974	948
Tariff 053	1.101	1.095	1.097	1.088	949
Tariff 054	0.990	0.991	0.988	0.989	953
Tariff 055	0.972	0.973	0.982	0.981	954
Tariff 057	0.923	0.924	0.932	0.930	956
Tariff 058	0.997	0.997	0.997	0.997	958
Tariff 059	1.027	1.027	1.027	1.028	529
Tariff 060	1.079	1.132	1.165	1.197	961
Tariff 061	0.962	0.961	0.961	0.960	8694
Tariff 062	0.962	0.961	0.961	0.960	8694
Tariff 063	0.996	0.996	0.996	0.996	962
Tariff 064	1.012	1.013	1.033	1.033	963
Tariff 065	0.991	0.992	0.991	0.992	967
Tariff 067	0.992	0.993	0.993	0.994	969

EHV site specific LLFs					
Generation					
Site	Period 1	Period 2	Period 3	Period 4	Associated LLFC
Tariff 068	N/A	N/A	N/A	N/A	8687
Tariff 069	0.990	0.990	0.990	0.991	972
Tariff 070	0.975	0.976	0.975	0.975	973
Tariff 071	0.975	0.975	0.974	0.974	974
Tariff 072	0.987	0.987	0.987	0.987	833
Tariff 073	0.990	0.990	0.990	0.990	975
Tariff 074	0.890	0.892	0.901	0.897	977
Tariff 075	0.988	0.988	0.988	0.988	979
Tariff 079	0.990	0.992	0.991	0.991	983
Tariff 080	0.990	0.992	0.991	0.991	984
Tariff 081	0.985	1.002	0.998	1.012	985
Tariff 082	0.977	0.976	0.976	0.976	986
Tariff 083	N/A	N/A	N/A	N/A	8689
Tariff 084	N/A	N/A	N/A	N/A	8689
Tariff 085	0.999	0.998	0.998	0.998	989
Tariff 086	0.971	0.971	0.970	0.971	991
Tariff 087	0.978	0.976	0.975	0.975	8740
Tariff 088	1.004	1.005	1.006	1.004	807
Tariff 089	0.994	0.994	0.993	0.993	808
Tariff 090	1.005	1.017	1.017	1.012	929
Tariff 091	1.132	1.129	1.139	1.121	809
Tariff 093	1.002	1.017	1.014	1.014	810
Tariff 094	1.022	1.022	1.018	1.020	811
Tariff 095	1.020	1.020	1.016	1.018	812
Tariff 096	0.955	0.952	0.953	0.956	813
Tariff 097	1.016	1.018	1.016	1.013	814
Tariff 098	1.022	1.019	1.019	1.015	815
Tariff 106	1.003	1.006	1.005	1.002	855
Tariff 112	1.000	1.000	1.000	1.000	838
Tariff 122	1.000	1.000	1.000	1.000	900
Tariff 123	1.000	1.000	1.000	1.000	900
Tariff 124	1.000	1.000	1.000	1.000	900
Tariff 125	1.000	1.000	1.000	1.000	900
Tariff 128	0.997	0.995	0.994	0.993	816
Tariff 129	0.988	0.987	0.985	0.985	817
Tariff 130	1.011	1.009	1.007	1.007	818
Tariff 131	1.013	1.012	1.011	1.011	819
Tariff 132	0.971	0.971	0.971	0.971	820
Tariff 133	1.034	1.054	1.067	1.065	821
Tariff 134	0.996	0.996	0.996	0.996	822
Tariff 135	1.069	1.121	1.181	1.155	823
Tariff 136	1.004	1.006	1.006	1.005	825
Tariff 137	1.001	1.001	1.001	1.000	826
Tariff 138	0.999	0.998	0.998	0.998	966
Tariff 140	0.988	0.988	0.988	0.988	8710
Tariff 141	0.995	0.995	0.995	0.995	830
Tariff 143	0.989	0.989	0.989	0.989	834
Tariff 144	0.964	0.965	0.965	0.964	835
Tariff 146	0.979	0.979	0.979	0.979	990
Tariff 147	0.991	0.991	0.991	0.991	844
Tariff 149	1.021	1.018	1.017	1.013	846
Tariff 150	0.961	0.961	0.961	0.961	848
Tariff 151	0.994	0.994	0.993	0.994	8715

EHV site specific LLFs					
Generation					
Site	Period 1	Period 2	Period 3	Period 4	Associated LLFC
Tariff 153	0.928	0.927	0.926	0.928	852
Tariff 154	1.001	1.001	1.001	1.001	853
Tariff 155	0.996	0.996	0.996	0.996	854
Tariff 157	1.013	1.014	1.014	1.012	859
Tariff 158	0.941	0.935	0.931	0.935	860
Tariff 159	0.974	0.973	0.972	0.972	8717
Tariff 161	0.986	0.986	0.986	0.986	863
Tariff 162	1.000	1.000	1.011	1.005	864
Tariff 163	0.973	0.973	0.973	0.973	865
Tariff 165	1.132	1.132	1.126	1.106	867
Tariff 166	1.002	1.002	1.001	1.001	824
Tariff 170	0.991	0.991	0.991	0.991	870
Tariff 171	0.997	0.997	0.997	0.997	871
Tariff 172	1.003	1.004	1.009	1.006	978
Tariff 174	1.005	1.004	1.003	1.002	873
Tariff 179	1.027	1.027	1.027	1.028	528
Tariff 180	1.027	1.027	1.027	1.028	528
Tariff 181	1.027	1.027	1.027	1.028	528
Tariff 182	1.027	1.027	1.027	1.028	528
Tariff 183	1.027	1.027	1.027	1.028	528
Tariff 184	1.027	1.027	1.027	1.028	528
Tariff 185	1.027	1.027	1.027	1.028	528
Tariff 186	1.027	1.027	1.027	1.028	528
Tariff 187	1.027	1.027	1.027	1.028	528
Tariff 188	1.000	1.000	1.000	1.000	843
Tariff 189	1.000	1.000	1.000	1.000	843
Tariff 190	1.000	1.000	1.000	1.000	843
Tariff 191	0.996	0.997	0.994	0.993	874
Tariff 192	0.954	0.955	0.952	0.953	875
Tariff 194	0.992	0.992	0.992	0.992	980
Tariff 196	1.003	1.004	1.004	1.004	879
Tariff 197	0.993	0.993	0.993	0.993	847
Tariff 202	0.997	0.997	0.997	0.997	881
Tariff 203	1.034	1.069	1.094	1.070	882
Tariff 204	1.000	1.001	0.999	0.999	883
Tariff 206	0.988	0.987	0.987	0.987	885
Tariff 207	1.005	1.005	1.006	1.004	886
Tariff 208	0.996	0.996	0.996	0.996	887
Tariff 209	0.940	0.939	0.938	0.938	888
Tariff 212	0.987	0.987	0.987	0.986	891
Tariff 214	1.109	1.130	1.114	1.108	893
Tariff 215	0.996	0.996	0.996	0.996	8720
Tariff 216	0.977	0.976	0.976	0.976	895
Tariff 217	0.969	0.968	0.968	0.967	896
Tariff 221	1.043	1.037	1.044	1.039	856
Tariff 230	0.977	0.977	0.976	0.976	8719
Tariff 232	0.991	0.991	0.991	0.990	908
Tariff 234	1.057	1.054	1.050	1.054	831
Tariff 235	1.005	1.008	1.006	1.007	836
Tariff 237	1.014	1.012	1.013	1.010	971
Tariff 238	1.000	1.000	1.000	1.000	8707
Tariff 240	0.991	0.991	0.991	0.991	828
Tariff 241	0.993	0.992	0.992	0.993	981

EHV site specific LLFs					
Generation					
Site	Period 1	Period 2	Period 3	Period 4	Associated LLFC
Tariff 242	1.000	1.000	1.000	1.000	839
Tariff 246	0.996	0.996	0.996	0.996	8722
Tariff 249	0.978	0.978	0.977	0.978	970
Tariff 251	0.949	0.949	0.949	0.948	876
Tariff 252	0.958	0.958	0.958	0.958	880
Tariff 253	1.008	1.006	1.008	1.008	840
Tariff 254	0.937	0.937	0.937	0.937	829
Tariff 255	0.966	0.966	0.966	0.966	8741
Tariff 256	1.004	1.004	1.004	1.003	841
Tariff 257	0.995	0.995	0.995	0.995	982
Tariff 258	0.983	0.983	0.983	0.983	531
Tariff 259	0.959	0.959	0.954	0.954	845
Tariff 260	1.014	1.008	1.007	1.012	849
Tariff 262	0.969	0.969	0.969	0.969	992
Tariff 263	1.029	1.029	1.031	1.031	934
Tariff 265	1.025	1.024	1.023	1.022	933
Tariff 266	1.014	1.014	1.009	1.009	960
Tariff 269	0.969	0.969	0.972	0.971	995
Tariff 273	0.996	0.995	0.995	0.993	964
Tariff 274	0.987	0.987	0.987	0.987	827
Tariff 277	0.990	0.999	0.996	1.003	898
Tariff 282	1.013	1.022	1.023	1.025	996
Tariff 286	0.953	0.954	0.953	0.952	842
Tariff 287	0.999	0.999	0.999	0.999	899
Tariff 288	0.966	0.966	0.966	0.966	8727
Tariff 289	0.958	0.958	0.957	0.957	902
Tariff 290	0.995	0.995	0.996	0.996	912
Tariff 291	1.005	1.007	1.006	1.006	994
Tariff 292	1.024	1.027	1.024	1.021	916
Tariff 295	1.007	1.004	1.003	1.004	919
Tariff 296	1.014	1.014	1.013	1.008	965
Tariff 299	0.974	0.973	0.974	0.973	8755
Tariff 300	1.014	1.014	1.009	1.009	960
Tariff 302	1.017	1.014	1.020	1.017	976
Tariff 303	1.015	1.012	1.017	1.015	857
Tariff 311	0.998	0.998	0.998	0.998	533
Tariff 312	0.996	0.996	0.996	0.996	947
Tariff 317	0.994	0.998	0.998	0.997	957
Tariff 320	1.000	1.000	1.000	1.000	872
Tariff 322	1.000	0.999	0.998	0.999	968
Tariff 327	0.978	0.978	0.978	0.978	894
Tariff 331	0.995	0.995	0.995	0.995	878
Tariff 334	0.949	0.950	0.950	0.950	911
Tariff 340	0.999	0.996	0.996	0.999	920
Tariff 342	1.000	1.000	1.000	1.000	8756
Tariff 348	1.013	1.018	1.006	1.009	988
Tariff 350	1.014	1.014	1.009	1.009	960
Tariff 355	1.024	1.027	1.024	1.021	921
Tariff 356	1.000	1.000	1.000	1.000	998
Tariff 357	1.009	1.007	1.007	1.004	8738
Tariff 358	1.021	1.017	1.025	1.022	959
Tariff 359	1.006	1.004	1.004	1.005	901
Tariff 362	0.984	0.984	0.984	0.984	905

EHV site specific LLFs					
Generation					
Site	Period 1	Period 2	Period 3	Period 4	Associated LLFC
Tariff 364	0.998	0.998	0.998	0.998	8737
Tariff 365	1.000	1.000	1.000	1.000	862
Tariff 367	1.000	1.000	1.000	1.000	8743
Tariff 369	0.972	0.972	0.972	0.972	8757
Tariff 372	0.987	0.986	0.986	0.987	897
Tariff 375	1.014	1.014	1.009	1.009	960
Tariff 377	0.960	0.961	0.961	0.961	907
Tariff 379	0.916	0.916	0.916	0.917	997
Tariff 380	0.969	0.969	0.969	0.969	892
Tariff 381	0.999	0.999	0.999	0.999	993
Tariff 383	1.014	1.014	1.009	1.009	960
Tariff 387	1.010	1.007	1.007	1.003	858
Tariff 389	0.972	0.972	0.968	0.972	532
Tariff 390	1.014	1.014	1.009	1.009	960
Tariff 392	1.027	1.027	1.027	1.028	538
Tariff 393	1.014	1.014	1.009	1.009	8764
Tariff 396	1.014	1.014	1.009	1.009	960
Tariff 416	1.006	1.005	1.004	1.002	534
Tariff 426	1.014	1.014	1.009	1.009	960
Tariff 433	1.014	1.014	1.009	1.009	960
Tariff 434	1.014	1.014	1.009	1.009	960
Tariff 436	1.014	1.014	1.009	1.009	960
Tariff 439	1.014	1.014	1.009	1.009	960
Tariff 440	1.014	1.014	1.009	1.009	8760
Tariff 443	1.014	1.014	1.009	1.009	960
Tariff 444	1.014	1.014	1.009	1.009	960
Tariff 445	1.014	1.014	1.009	1.009	960
Tariff 446	1.014	1.014	1.009	1.009	960
Tariff 447	1.014	1.014	1.009	1.009	960
Tariff 448	1.014	1.014	1.009	1.009	960
Tariff 449	1.014	1.014	1.009	1.009	960
Tariff 450	1.014	1.014	1.009	1.009	960

Annex 6 – Charges for New or Amended Designated EHV Properties

Note: The list of MPANs / MSIDs provided may be incomplete; the DNO reserves the right to apply the listed charges to any other MPANs / MSIDs associated with the site.

Scottish Hydro Electric Power Distribution plc - Effective from 1 April 2022 - Final new or amended designated EHV charges													
Effective from date	Import LLFC	Import MPANs/MSIDs	Export LLFC	Export MPANs/MSIDs	Name	Import Super Red unit charge (p/kWh)	Import fixed charge (p/day)	Import capacity charge (p/kVA/day)	Import exceeded capacity charge (p/kVA/day)	Export Super Red unit charge (p/kWh)	Export fixed charge (p/day)	Export capacity charge (p/kVA/day)	Export exceeded capacity charge (p/kVA/day)
01/04/2022	799	-	960	-	Tariff 424	0.000	610.19	0.50	0.50	0.000	610.19	0.05	0.05
01/04/2022	799	-	960	-	Tariff 451	0.000	7.52	0.72	0.72	0.000	752.08	0.05	0.05
01/04/2022	565	1721843065002	525	1700051732268	Tariff 013	0.000	2431.52	1.35	1.35	0.000	0.00	0.00	0.00
01/04/2022	567	1700052157576	527	1700052157585	Tariff 015	1.784	2330.24	5.65	5.65	0.000	0.00	0.00	0.00
01/04/2022	713	1712380671009	913	1700051748160	Tariff 017	0.000	2332.01	0.38	0.38	0.000	0.00	0.00	0.00
01/04/2022	8707	8707	8707	8707	Tariff 020	0.000	2329.69	1.52	1.52	0.000	0.00	0.00	0.00
01/04/2022	637	1700051778208	837	1700051771578	Tariff 023	0.000	2335.68	0.95	0.95	0.000	0.00	0.00	0.00
01/04/2022	8328	8328	8328	8328	Tariff 024	0.000	2363.65	1.31	1.31	0.000	15775.28	0.05	0.05
01/04/2022	8696	8696	8696	8696	Tariff 026	0.000	2332.28	1.59	1.59	0.000	0.00	0.00	0.00
01/04/2022	8699	8699	8699	8699	Tariff 031	0.000	2410.23	0.68	0.68	0.000	0.00	0.00	0.00
01/04/2022	8699	8699	8699	8699	Tariff 032	0.000	2410.23	0.68	0.68	0.000	0.00	0.00	0.00
01/04/2022	732	1700052249980	932	1700052249999	Tariff 037	0.000	2336.14	0.71	0.71	0.000	1626.59	0.05	0.05
01/04/2022	740	1700051754313	940	1700051781520	Tariff 045	0.000	2367.32	0.94	0.94	0.000	0.00	0.00	0.00
01/04/2022	8694	8694	8694	8694	Tariff 061	0.000	2332.96	1.45	1.45	0.000	0.00	0.00	0.00

01/04/2022	8694	8694	8694	8694	Tariff 062	0.000	2347.17	1.37	1.37	0.000	0.00	0.00	0.00
01/04/2022	8687	8687	8687	8687	Tariff 068	0.000	2330.12	0.65	0.65	0.000	160.32	0.05	0.05
01/04/2022	8740	8740	8740	8740	Tariff 087	0.000	2333.34	4.13	4.13	0.000	3563.66	0.05	0.05
01/04/2022	620	1700052464740	820	1700052464759	Tariff 132	0.000	2664.68	2.30	2.30	0.000	856.94	0.05	0.05
01/04/2022	623	1700052434197	823	1700052434211	Tariff 135	0.000	2334.46	0.86	0.86	0.000	805.95	0.05	0.05
01/04/2022	630	1700052708187	830	1700052708196	Tariff 141	0.000	2550.19	1.08	1.08	0.000	761.85	0.05	0.05
01/04/2022	644	1700051778192	844	1700051778183	Tariff 147	0.000	2365.10	0.45	0.45	0.000	0.00	0.00	0.00
01/04/2022	8715	8715	8715	8715	Tariff 151	0.000	2344.02	3.86	3.86	0.000	7725.84	0.05	0.05
01/04/2022	669	1700052611323	875	1700052611332	Tariff 192	0.000	2390.36	1.40	1.40	0.000	7319.88	0.05	0.05
01/04/2022	675	1700052707945	881	1700052707963	Tariff 202	0.000	2810.86	1.24	1.24	0.000	1476.59	0.05	0.05
01/04/2022	8719	8719	8719	8719	Tariff 230	0.000	2542.72	0.57	0.57	0.000	12404.57	0.05	0.05
01/04/2022	631	1700052750685	831	1700052750694	Tariff 234	0.000	2380.77	0.71	0.71	0.000	616.95	0.05	0.05
01/04/2022	8707	8707	8707	8707	Tariff 238	0.000	2332.08	0.51	0.51	0.000	0.00	0.00	0.00
01/04/2022	639	1700052751331	839	1700052751340	Tariff 242	0.000	2468.41	0.66	0.66	0.000	2398.59	0.05	0.05
01/04/2022	8722	8722	8722	8722	Tariff 246	0.000	3099.17	0.46	0.46	0.000	28482.90	0.05	0.05
01/04/2022	640	1700052750408	840	1700052750417	Tariff 253	0.000	2346.26	0.69	0.69	0.000	777.19	0.05	0.05
01/04/2022	8741	8741	8741	8741	Tariff 255	0.000	2468.96	0.79	0.79	0.000	31409.58	0.05	0.05
01/04/2022	693	1700052810094	933	1700052810100	Tariff 265	0.000	2503.75	0.87	0.87	0.000	1150.96	0.05	0.05
01/04/2022	8727	8727	8727	8727	Tariff 288	0.000	2538.50	1.09	1.09	0.000	35852.10	0.05	0.05
01/04/2022	716	1700052889721	916	1700052889730	Tariff 292	0.000	2330.35	0.88	0.88	0.000	495.82	0.05	0.05
01/04/2022	585	1700053106800	8755	8755	Tariff 299	0.000	2333.58	0.84	0.84	0.000	492.59	0.05	0.05

01/04/2022	799	1700052918959	960	1700052918968	Tariff 300	0.000	2432.17	1.51	1.51	0.000	1151.44	0.05	0.05
01/04/2022	8752	8752	8756	8756	Tariff 342	0.000	2341.64	0.48	0.48	0.000	1218.19	0.05	0.05
01/04/2022	721	1700052954655	921	1700052954664	Tariff 355	0.000	2330.59	0.81	0.81	0.000	614.57	0.05	0.05
01/04/2022	8743	8743	8743	8743	Tariff 367	0.000	2337.50	0.94	0.94	0.000	488.67	0.05	0.05
01/04/2022	593	1700053187039	532	1700053187048	Tariff 389	0.000	3123.93	0.78	0.78	0.000	29872.71	0.05	0.05
01/04/2022	584	1700053240055	534	1700053240064	Tariff 416	0.000	2335.18	1.30	1.30	0.000	820.63	0.05	0.05

Scottish Hydro Electric Power Distribution plc - Effective from 1 April 2022 - Final new or amended designated EHV line loss factors

Effective from date	Import LLFC	Import MPANs/MSIDs	Export LLFC	Export MPANs/MSIDs	Tariff	Import LLF period 1	Import LLF period 2	Import LLF period 3	Import LLF period 4	Export LLF period 1	Export LLF period 2	Export LLF period 3	Export LLF period 4
01/04/2022	799	-	960	-	Tariff 424	1.014	1.014	1.009	1.009	1.014	1.014	1.009	1.009
01/04/2022	799	-	960	-	Tariff 451	1.014	1.014	1.009	1.009	1.014	1.014	1.009	1.009

Annex 7 – Supplier of last Resort and Eligible Bad Debt Pass-Through Costs

Scottish Hydro Electric Power Distribution plc - Effective from 1 April 2022 - Final Supplier of Last Resort and Eligible Bad Debt Pass-Through Costs

Tariff name	Open LLFCs / LDNO unique billing identifier	PCs	Supplier of Last Resort Fixed charge adder* p/MPAN/day	Excess Supplier of Last Resort Fixed charge adder** p/MPAN/day	Eligible Bad Debt Fixed charge adder*** p/MPAN/day
Domestic Aggregated with Residual	15, 18, 25, 27, 100-101, 105-106, 110-111, 120-121, 125-128, 300-301, 305, 320-321, 325, 506	0, 1, 2	0.03	9.85	0.05
Non-Domestic Aggregated No Residual	P60, P65, P70, P00, R35, R40, P05, P10, P15, P20, P25, P30, P35, P40, R45, P45, P50, P55, R50, P75, R55, R60, R65, R70, R75, R80, R85, R90, R95, S05, S10	0, 3, 4, 5-8			0.05
Non-Domestic Aggregated Band 1	P61, P66, P71, P01, R36, R41, P06, P11, P16, P21, P26, P31, P36, P41, R46, P46, P51, P56, R51, P76, R56, R61, R66, R71, R76, R81, R86, R91, R96, S06, S11	0, 3, 4, 5-8			0.05
Non-Domestic Aggregated Band 2	P62, P67, P72, P02, R37, R42, P07, P12, P17, P22, P27, P32, P37, P42, R47, P47, P52, P57, R52, P77, R57, R62, R67, R72, R77, R82, R87, R92, R97, S07, S12	0, 3, 4, 5-8			0.05
Non-Domestic Aggregated Band 3	P63, P68, P73, P03, R38, R43, P08, P13, P18, P23, P28, P33, P38, P43, R48,	0, 3, 4, 5-8			0.05

Tariff name	Open LLCs / LDNO unique billing identifier	PCs	Supplier of Last Resort Fixed charge adder* p/MPAN/day	Excess Supplier of Last Resort Fixed charge adder** p/MPAN/day	Eligible Bad Debt Fixed charge adder*** p/MPAN/day
	P48, P53, P58, R53, P78, R58, R63, R68, R73, R78, R83, R88, R93, R98, S08, S13				
Non-Domestic Aggregated Band 4	P64, P69, P74, P04, R39, R44, P09, P14, P19, P24, P29, P34, P39, P44, R49, P49, P54, P59, R54, P79, R59, R64, R69, R74, R79, R84, R89, R94, R99, S09, S14	0, 3, 4, 5-8			0.05
LV Site Specific No Residual	P80, 31	0			0.05
LV Site Specific Band 1	P81	0			0.05
LV Site Specific Band 2	P82	0			0.05
LV Site Specific Band 3	P83	0			0.05
LV Site Specific Band 4	P84	0			0.05
LV Sub Site Specific No Residual	P85, 32	0			0.05
LV Sub Site Specific Band 1	P86	0			0.05
LV Sub Site Specific Band 2	P87	0			0.05
LV Sub Site Specific Band 3	P88	0			0.05

Tariff name	Open LLFCs / LDNO unique billing identifier	PCs	Supplier of Last Resort Fixed charge adder* p/MPAN/day	Excess Supplier of Last Resort Fixed charge adder** p/MPAN/day	Eligible Bad Debt Fixed charge adder*** p/MPAN/day
LV Sub Site Specific Band 4	P89	0			0.05
HV Site Specific No Residual	P90, 604	0			0.05
HV Site Specific Band 1	P91	0			0.05
HV Site Specific Band 2	P92	0			0.05
HV Site Specific Band 3	P93	0			0.05
HV Site Specific Band 4	P94	0			0.05
LDNO LV: Domestic Aggregated with Residual		0, 1, 2	0.03	9.85	0.05
LDNO LV: Non-Domestic Aggregated No Residual		0, 3, 4, 5-8			0.05
LDNO LV: Non-Domestic Aggregated Band 1		0, 3, 4, 5-8			0.05
LDNO LV: Non-Domestic Aggregated Band 2		0, 3, 4, 5-8			0.05
LDNO LV: Non-Domestic Aggregated Band 3		0, 3, 4, 5-8			0.05
LDNO LV: Non-Domestic Aggregated Band 4		0, 3, 4, 5-8			0.05
LDNO LV: LV Site Specific No Residual		0			0.05

Tariff name	Open LLFCs / LDNO unique billing identifier	PCs	Supplier of Last Resort Fixed charge adder* p/MPAN/day	Excess Supplier of Last Resort Fixed charge adder** p/MPAN/day	Eligible Bad Debt Fixed charge adder*** p/MPAN/day
LDNO LV: LV Site Specific Band 1		0			0.05
LDNO LV: LV Site Specific Band 2		0			0.05
LDNO LV: LV Site Specific Band 3		0			0.05
LDNO LV: LV Site Specific Band 4		0			0.05
LDNO HV: Domestic Aggregated with Residual		0, 1, 2	0.03	9.85	0.05
LDNO HV: Non-Domestic Aggregated No Residual		0, 3, 4, 5-8			0.05
LDNO HV: Non-Domestic Aggregated Band 1		0, 3, 4, 5-8			0.05
LDNO HV: Non-Domestic Aggregated Band 2		0, 3, 4, 5-8			0.05
LDNO HV: Non-Domestic Aggregated Band 3		0, 3, 4, 5-8			0.05
LDNO HV: Non-Domestic Aggregated Band 4		0, 3, 4, 5-8			0.05
LDNO HV: LV Site Specific No Residual		0			0.05
LDNO HV: LV Site Specific Band 1		0			0.05
LDNO HV: LV Site Specific Band 2		0			0.05

Tariff name	Open LLFCs / LDNO unique billing identifier	PCs	Supplier of Last Resort Fixed charge adder* p/MPAN/day	Excess Supplier of Last Resort Fixed charge adder** p/MPAN/day	Eligible Bad Debt Fixed charge adder*** p/MPAN/day
LDNO HV: LV Site Specific Band 3		0			0.05
LDNO HV: LV Site Specific Band 4		0			0.05
LDNO HV: LV Sub Site Specific No Residual		0			0.05
LDNO HV: LV Sub Site Specific Band 1		0			0.05
LDNO HV: LV Sub Site Specific Band 2		0			0.05
LDNO HV: LV Sub Site Specific Band 3		0			0.05
LDNO HV: LV Sub Site Specific Band 4		0			0.05
LDNO HV: HV Site Specific No Residual		0			0.05
LDNO HV: HV Site Specific Band 1		0			0.05
LDNO HV: HV Site Specific Band 2		0			0.05
LDNO HV: HV Site Specific Band 3		0			0.05
LDNO HV: HV Site Specific Band 4		0			0.05
LDNO HVplus: Domestic Aggregated with Residual		0, 1, 2	0.03	9.85	0.05

Tariff name	Open LLFCs / LDNO unique billing identifier	PCs	Supplier of Last Resort Fixed charge adder* p/MPAN/day	Excess Supplier of Last Resort Fixed charge adder** p/MPAN/day	Eligible Bad Debt Fixed charge adder*** p/MPAN/day
LDNO HVplus: Non-Domestic Aggregated No Residual		0, 3, 4, 5-8			0.05
LDNO HVplus: Non-Domestic Aggregated Band 1		0, 3, 4, 5-8			0.05
LDNO HVplus: Non-Domestic Aggregated Band 2		0, 3, 4, 5-8			0.05
LDNO HVplus: Non-Domestic Aggregated Band 3		0, 3, 4, 5-8			0.05
LDNO HVplus: Non-Domestic Aggregated Band 4		0, 3, 4, 5-8			0.05
LDNO HVplus: LV Site Specific No Residual		0			0.05
LDNO HVplus: LV Site Specific Band 1		0			0.05
LDNO HVplus: LV Site Specific Band 2		0			0.05
LDNO HVplus: LV Site Specific Band 3		0			0.05
LDNO HVplus: LV Site Specific Band 4		0			0.05
LDNO HVplus: LV Sub Site Specific No Residual		0			0.05
LDNO HVplus: LV Sub Site Specific Band 1		0			0.05
LDNO HVplus: LV Sub Site Specific Band 2		0			0.05

Tariff name	Open LLFCs / LDNO unique billing identifier	PCs	Supplier of Last Resort Fixed charge adder* p/MPAN/day	Excess Supplier of Last Resort Fixed charge adder** p/MPAN/day	Eligible Bad Debt Fixed charge adder*** p/MPAN/day
LDNO HVplus: LV Sub Site Specific Band 3		0			0.05
LDNO HVplus: LV Sub Site Specific Band 4		0			0.05
LDNO HVplus: HV Site Specific No Residual		0			0.05
LDNO HVplus: HV Site Specific Band 1		0			0.05
LDNO HVplus: HV Site Specific Band 2		0			0.05
LDNO HVplus: HV Site Specific Band 3		0			0.05
LDNO HVplus: HV Site Specific Band 4		0			0.05
LDNO EHV: Domestic Aggregated with Residual		0, 1, 2	0.03	9.85	0.05
LDNO EHV: Non-Domestic Aggregated No Residual		0, 3, 4, 5-8			0.05
LDNO EHV: Non-Domestic Aggregated Band 1		0, 3, 4, 5-8			0.05
LDNO EHV: Non-Domestic Aggregated Band 2		0, 3, 4, 5-8			0.05
LDNO EHV: Non-Domestic Aggregated Band 3		0, 3, 4, 5-8			0.05
LDNO EHV: Non-Domestic Aggregated Band 4		0, 3, 4, 5-8			0.05

Tariff name	Open LLFCs / LDNO unique billing identifier	PCs	Supplier of Last Resort Fixed charge adder* p/MPAN/day	Excess Supplier of Last Resort Fixed charge adder** p/MPAN/day	Eligible Bad Debt Fixed charge adder*** p/MPAN/day
LDNO EHV: LV Site Specific No Residual		0			0.05
LDNO EHV: LV Site Specific Band 1		0			0.05
LDNO EHV: LV Site Specific Band 2		0			0.05
LDNO EHV: LV Site Specific Band 3		0			0.05
LDNO EHV: LV Site Specific Band 4		0			0.05
LDNO EHV: LV Sub Site Specific No Residual		0			0.05
LDNO EHV: LV Sub Site Specific Band 1		0			0.05
LDNO EHV: LV Sub Site Specific Band 2		0			0.05
LDNO EHV: LV Sub Site Specific Band 3		0			0.05
LDNO EHV: LV Sub Site Specific Band 4		0			0.05
LDNO EHV: HV Site Specific No Residual		0			0.05
LDNO EHV: HV Site Specific Band 1		0			0.05
LDNO EHV: HV Site Specific Band 2		0			0.05

Tariff name	Open LLFCs / LDNO unique billing identifier	PCs	Supplier of Last Resort Fixed charge adder* p/MPAN/day	Excess Supplier of Last Resort Fixed charge adder** p/MPAN/day	Eligible Bad Debt Fixed charge adder*** p/MPAN/day
LDNO EHV: HV Site Specific Band 3		0			0.05
LDNO EHV: HV Site Specific Band 4		0			0.05
LDNO 132kV/EHV: Domestic Aggregated with Residual		0, 1, 2	0.03	9.85	0.05
LDNO 132kV/EHV: Non-Domestic Aggregated No Residual		0, 3, 4, 5-8			0.05
LDNO 132kV/EHV: Non-Domestic Aggregated Band 1		0, 3, 4, 5-8			0.05
LDNO 132kV/EHV: Non-Domestic Aggregated Band 2		0, 3, 4, 5-8			0.05
LDNO 132kV/EHV: Non-Domestic Aggregated Band 3		0, 3, 4, 5-8			0.05
LDNO 132kV/EHV: Non-Domestic Aggregated Band 4		0, 3, 4, 5-8			0.05
LDNO 132kV/EHV: LV Site Specific No Residual		0			0.05
LDNO 132kV/EHV: LV Site Specific Band 1		0			0.05
LDNO 132kV/EHV: LV Site Specific Band 2		0			0.05
LDNO 132kV/EHV: LV Site Specific Band 3		0			0.05
LDNO 132kV/EHV: LV Site Specific Band 4		0			0.05

Tariff name	Open LLFCs / LDNO unique billing identifier	PCs	Supplier of Last Resort Fixed charge adder* p/MPAN/day	Excess Supplier of Last Resort Fixed charge adder** p/MPAN/day	Eligible Bad Debt Fixed charge adder*** p/MPAN/day
LDNO 132kV/EHV: LV Sub Site Specific No Residual		0			0.05
LDNO 132kV/EHV: LV Sub Site Specific Band 1		0			0.05
LDNO 132kV/EHV: LV Sub Site Specific Band 2		0			0.05
LDNO 132kV/EHV: LV Sub Site Specific Band 3		0			0.05
LDNO 132kV/EHV: LV Sub Site Specific Band 4		0			0.05
LDNO 132kV/EHV: HV Site Specific No Residual		0			0.05
LDNO 132kV/EHV: HV Site Specific Band 1		0			0.05
LDNO 132kV/EHV: HV Site Specific Band 2		0			0.05
LDNO 132kV/EHV: HV Site Specific Band 3		0			0.05
LDNO 132kV/EHV: HV Site Specific Band 4		0			0.05
LDNO 132kV: Domestic Aggregated with Residual		0, 1, 2	0.03	9.85	0.05
LDNO 132kV: Non-Domestic Aggregated No Residual		0, 3, 4, 5-8			0.05
LDNO 132kV: Non-Domestic Aggregated Band 1		0, 3, 4, 5-8			0.05

Tariff name	Open LLFCs / LDNO unique billing identifier	PCs	Supplier of Last Resort Fixed charge adder* p/MPAN/day	Excess Supplier of Last Resort Fixed charge adder** p/MPAN/day	Eligible Bad Debt Fixed charge adder*** p/MPAN/day
LDNO 132kV: Non-Domestic Aggregated Band 2		0, 3, 4, 5-8			0.05
LDNO 132kV: Non-Domestic Aggregated Band 3		0, 3, 4, 5-8			0.05
LDNO 132kV: Non-Domestic Aggregated Band 4		0, 3, 4, 5-8			0.05
LDNO 132kV: LV Site Specific No Residual		0			0.05
LDNO 132kV: LV Site Specific Band 1		0			0.05
LDNO 132kV: LV Site Specific Band 2		0			0.05
LDNO 132kV: LV Site Specific Band 3		0			0.05
LDNO 132kV: LV Site Specific Band 4		0			0.05
LDNO 132kV: LV Sub Site Specific No Residual		0			0.05
LDNO 132kV: LV Sub Site Specific Band 1		0			0.05
LDNO 132kV: LV Sub Site Specific Band 2		0			0.05
LDNO 132kV: LV Sub Site Specific Band 3		0			0.05
LDNO 132kV: LV Sub Site Specific Band 4		0			0.05

Tariff name	Open LLFCs / LDNO unique billing identifier	PCs	Supplier of Last Resort Fixed charge adder* p/MPAN/day	Excess Supplier of Last Resort Fixed charge adder** p/MPAN/day	Eligible Bad Debt Fixed charge adder*** p/MPAN/day
LDNO 132kV: HV Site Specific No Residual		0			0.05
LDNO 132kV: HV Site Specific Band 1		0			0.05
LDNO 132kV: HV Site Specific Band 2		0			0.05
LDNO 132kV: HV Site Specific Band 3		0			0.05
LDNO 132kV: HV Site Specific Band 4		0			0.05
LDNO 0000: Domestic Aggregated with Residual		0, 1, 2	0.03	9.85	0.05
LDNO 0000: Non-Domestic Aggregated No Residual		0, 3, 4, 5-8			0.05
LDNO 0000: Non-Domestic Aggregated Band 1		0, 3, 4, 5-8			0.05
LDNO 0000: Non-Domestic Aggregated Band 2		0, 3, 4, 5-8			0.05
LDNO 0000: Non-Domestic Aggregated Band 3		0, 3, 4, 5-8			0.05
LDNO 0000: Non-Domestic Aggregated Band 4		0, 3, 4, 5-8			0.05
LDNO 0000: LV Site Specific No Residual		0			0.05
LDNO 0000: LV Site Specific Band 1		0			0.05

Tariff name	Open LLFCs / LDNO unique billing identifier	PCs	Supplier of Last Resort Fixed charge adder* p/MPAN/day	Excess Supplier of Last Resort Fixed charge adder** p/MPAN/day	Eligible Bad Debt Fixed charge adder*** p/MPAN/day
LDNO 0000: LV Site Specific Band 2		0			0.05
LDNO 0000: LV Site Specific Band 3		0			0.05
LDNO 0000: LV Site Specific Band 4		0			0.05
LDNO 0000: LV Sub Site Specific No Residual		0			0.05
LDNO 0000: LV Sub Site Specific Band 1		0			0.05
LDNO 0000: LV Sub Site Specific Band 2		0			0.05
LDNO 0000: LV Sub Site Specific Band 3		0			0.05
LDNO 0000: LV Sub Site Specific Band 4		0			0.05
LDNO 0000: HV Site Specific No Residual		0			0.05
LDNO 0000: HV Site Specific Band 1		0			0.05
LDNO 0000: HV Site Specific Band 2		0			0.05
LDNO 0000: HV Site Specific Band 3		0			0.05
LDNO 0000: HV Site Specific Band 4		0			0.05

*Supplier of Last Resort pass-through costs which are recovered on a two year lag allocated to all domestic tariffs with a fixed charge (including LDNO)

**Supplier of Last Resort pass-through costs which are not recovered on a two year lag allocated to all domestic tariffs with a fixed charge (including LDNO)

***Eligible Bad Debt pass-through costs allocated to all metered demand tariffs (including LDNO)